

Service Service Service



IT IS ONLY FOR Serial Number: NSxxxxxxx

Service Manual

TABLE OF CONTENTS

	Page
Specifications	1
Software Version Checking	2
Set Block Diagram.....	3-1
Set Wiring Diagram	3-2
Power Board.....	4
VR Board.....	5
LCD Board.....	6
Main & Aux Jack & Rect. Board.....	7
Set Mechanical Exploded View & Parts List.....	8



© Copyright 2009 Philips Consumer Electronics B.V. Eindhoven, The Netherlands
All rights reserved. No part of this publication may be reproduced, stored in a retrieval system or transmitted, in any form or by any means, electronic, mechanical, photocopying, or otherwise without the prior permission of Philips.

Published by SL 0945 Service Audio

Printed in The Netherlands

Subject to modification

3141 785 34521



Version 1.1



PHILIPS

SPECIFICATIONS

Dimensions (W x H x D)	341 x 122 x 236 mm
Weight (main unit)	1.67 kg
Power supply	DC 9V 1.5 A AC 110-127V, 60Hz 220-240V, 50Hz
Power consumption	Active <12 W
Power output	2 x 1 W RMS
Operating temperature range	-10 °C - 50 °C 14 °F -122 °F

SOFTWARE VERSION CHECKING**Software checking:**

Set at CD mode with no disc inserted --> then display shows "no" --> press and hold "Play" key for 5sec.
The software version will be showed on the display.

SET BLOCK DIAGRAM

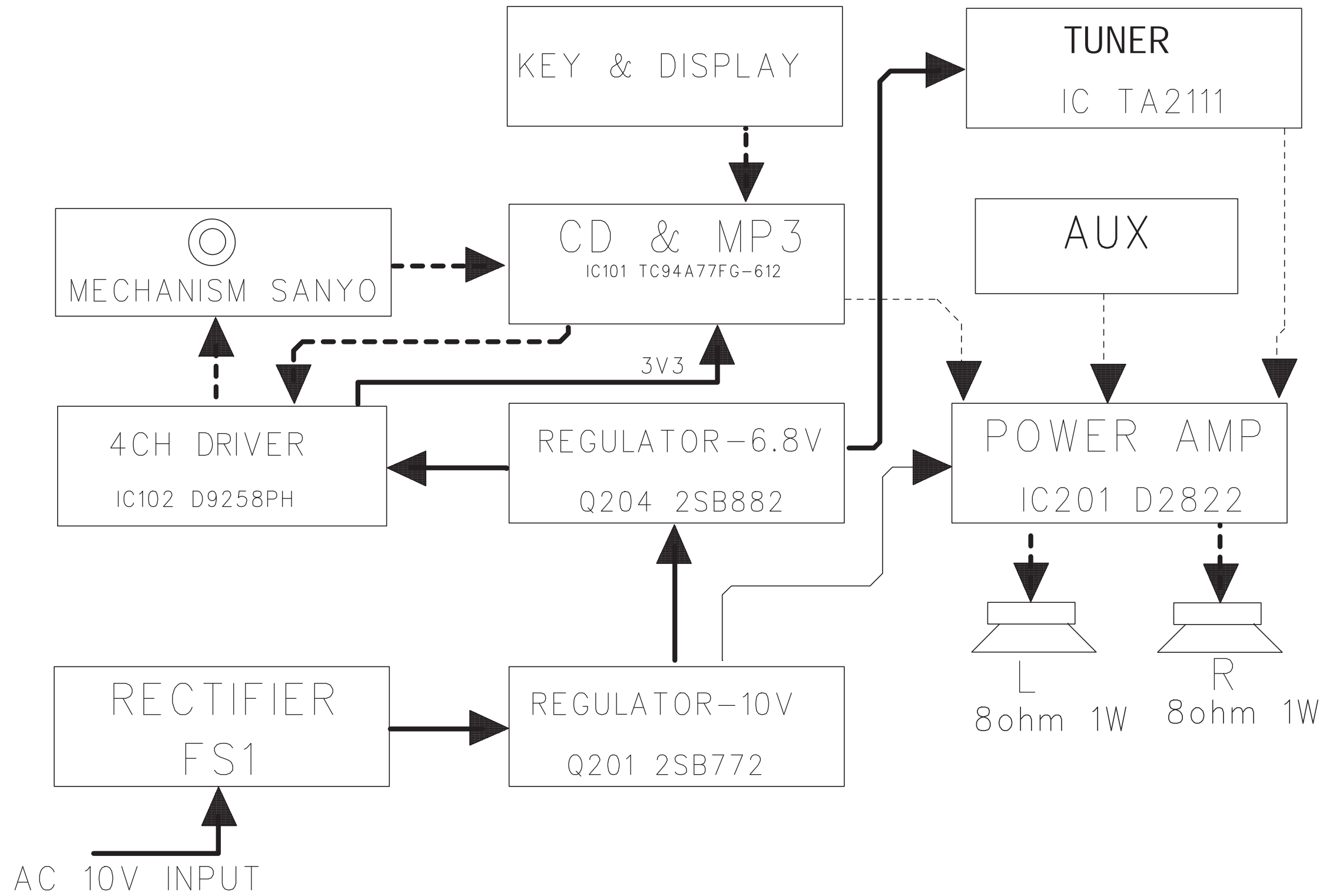

SET WIRING DIAGRAM

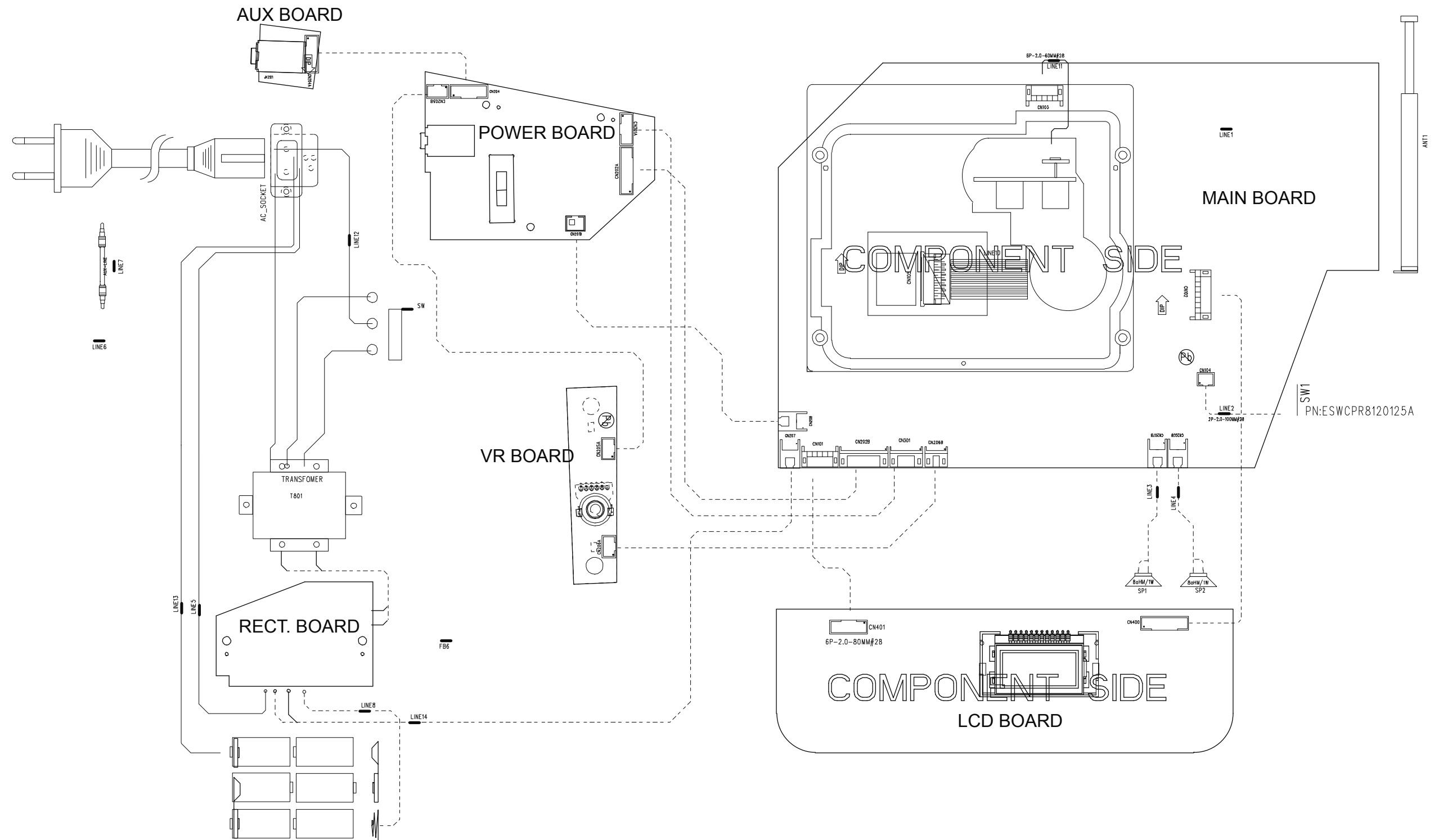

POWER BOARD - CIRCUIT DIAGRAM

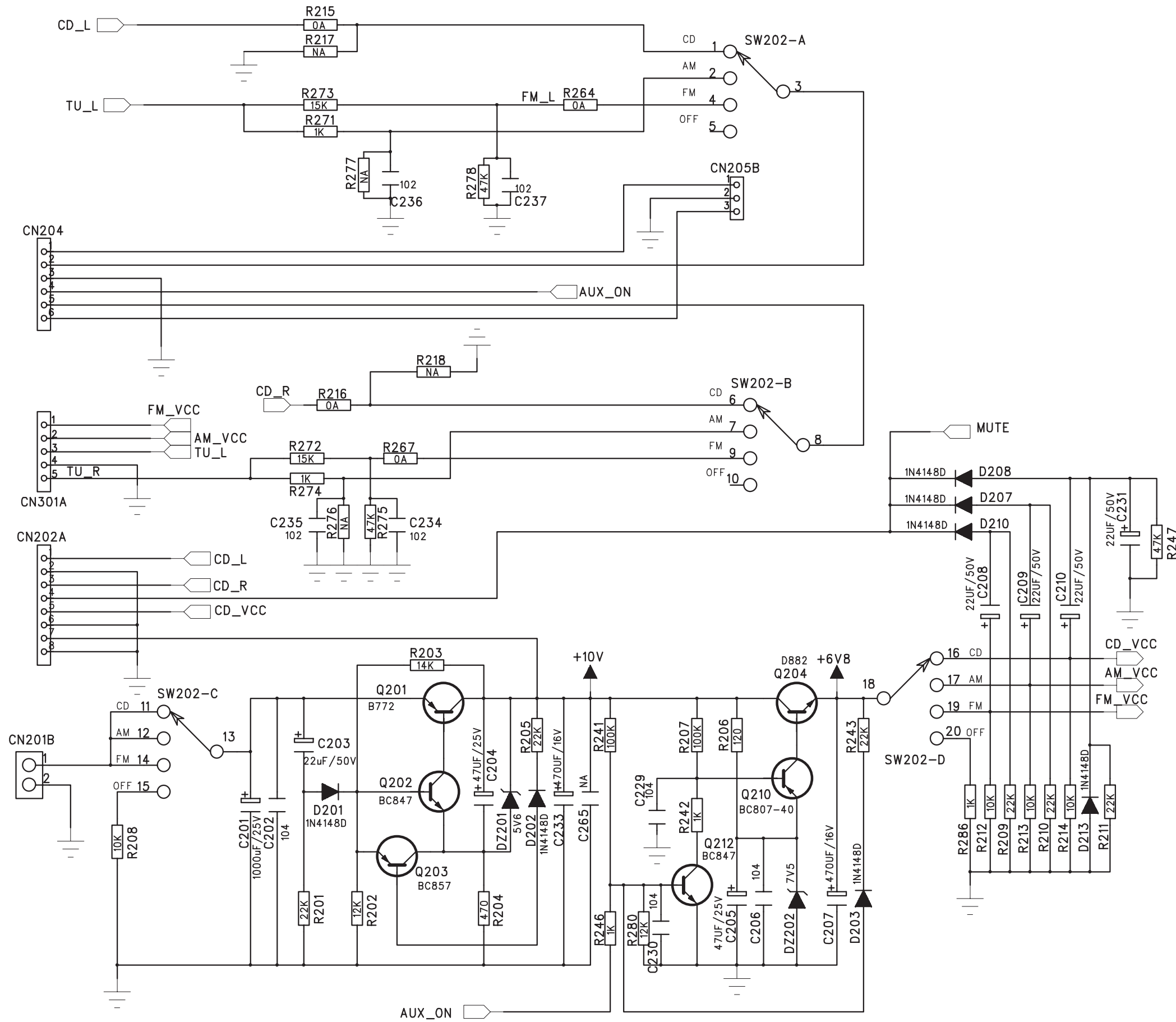

POWER BOARD - LAYOUT DIAGRAM
TOP VIEW

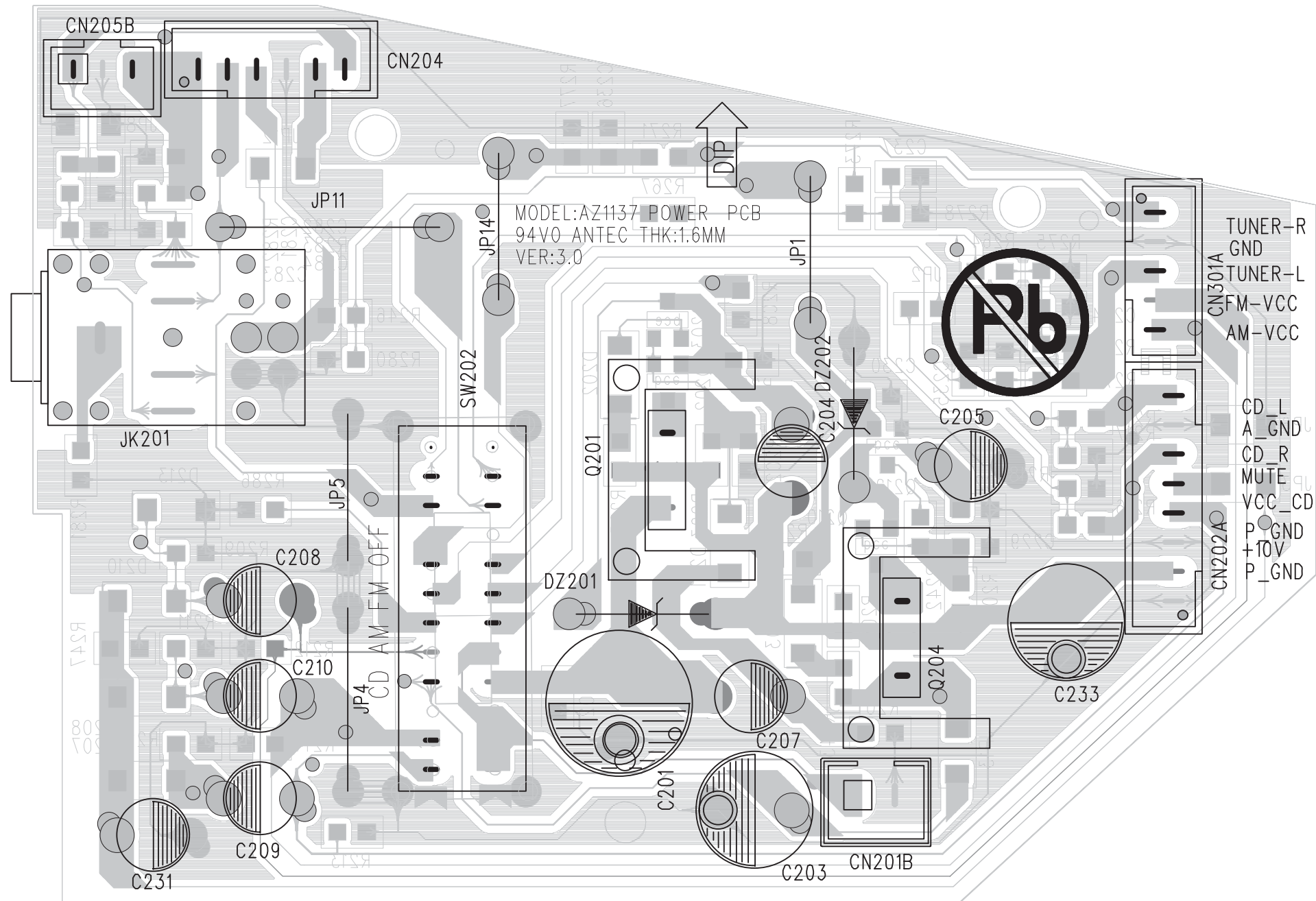

POWER BOARD - LAYOUT DIAGRAM
BOTTOM VIEW

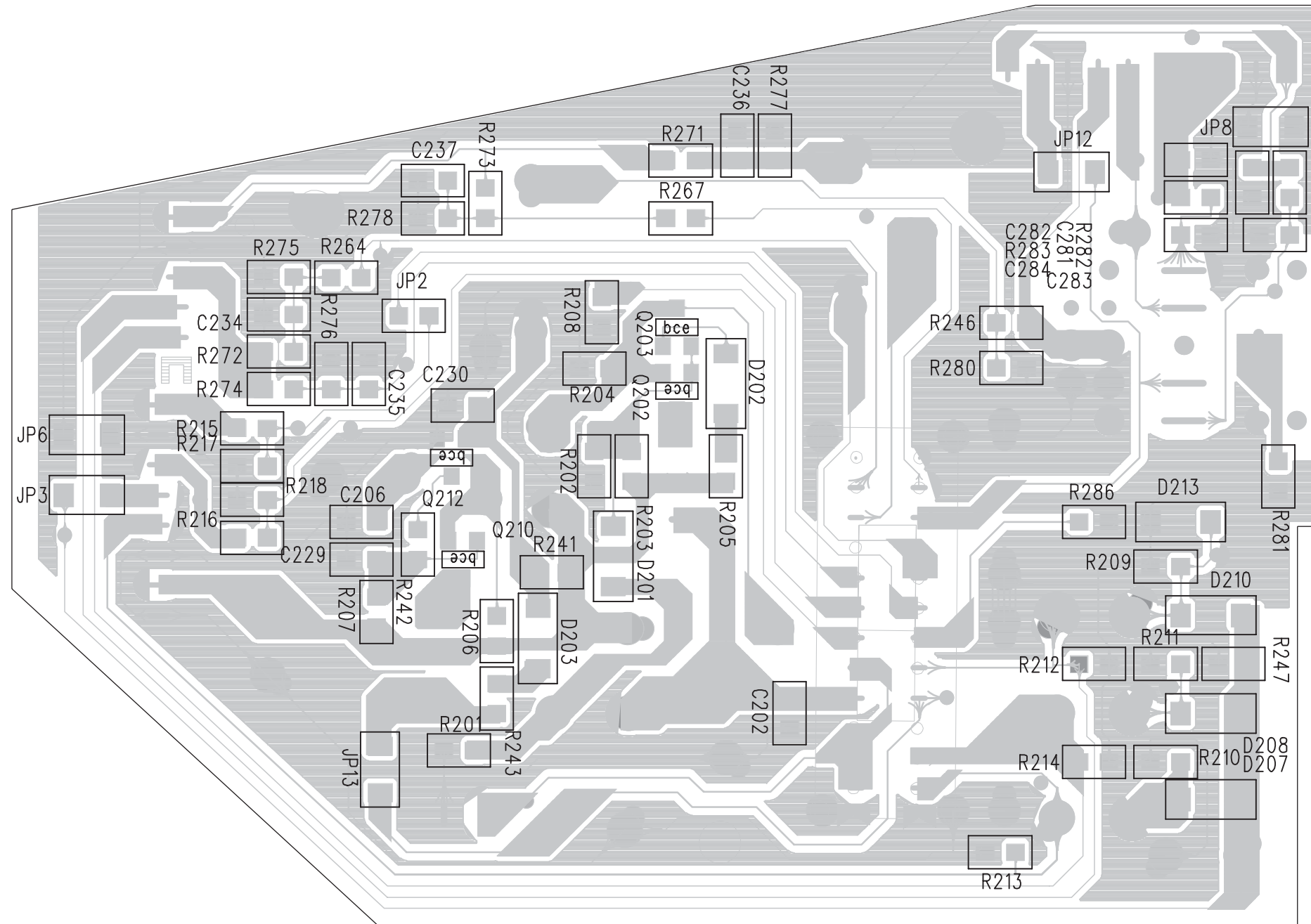

VR BOARD - CIRCUIT DIAGRAM

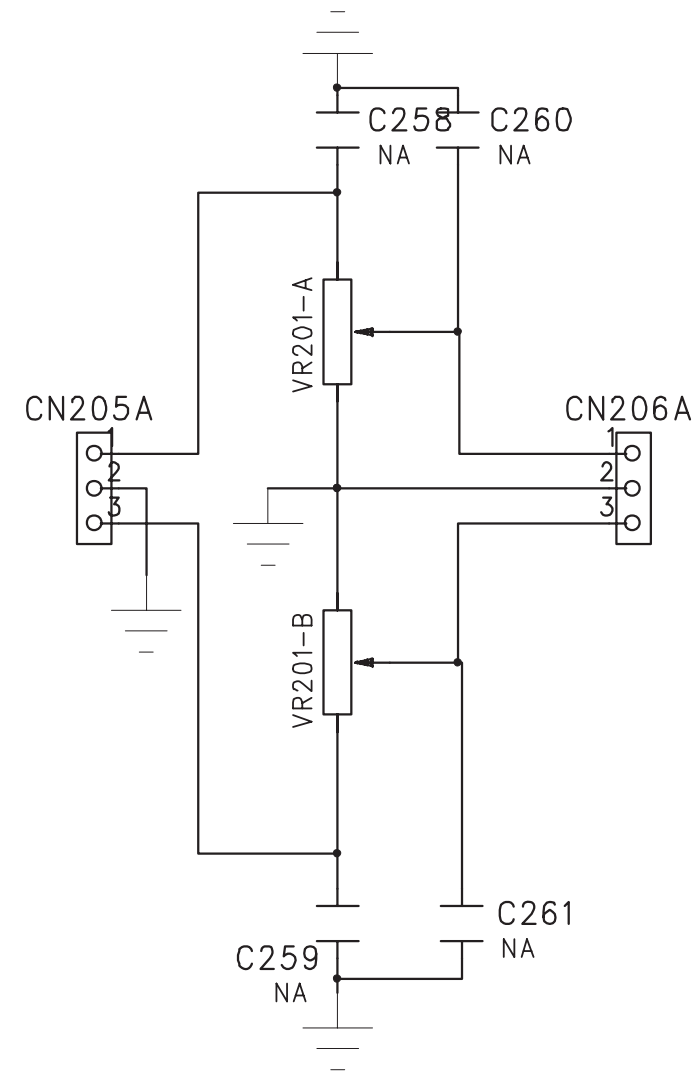

VR BOARD - LAYOUT DIAGRAM
TOP VIEW

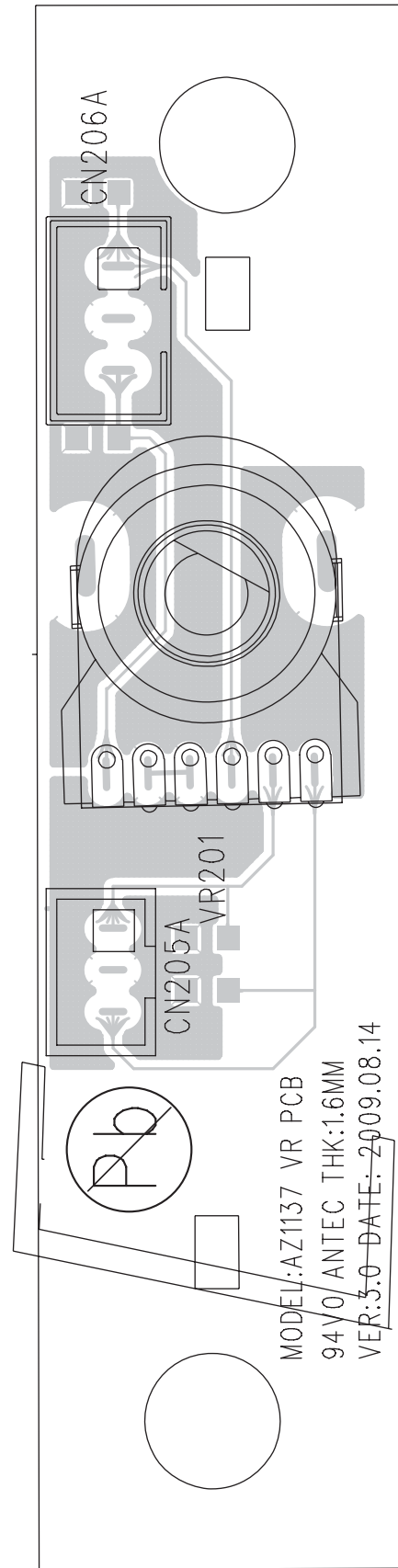

VR BOARD - LAYOUT DIAGRAM
BOTTOM VIEW

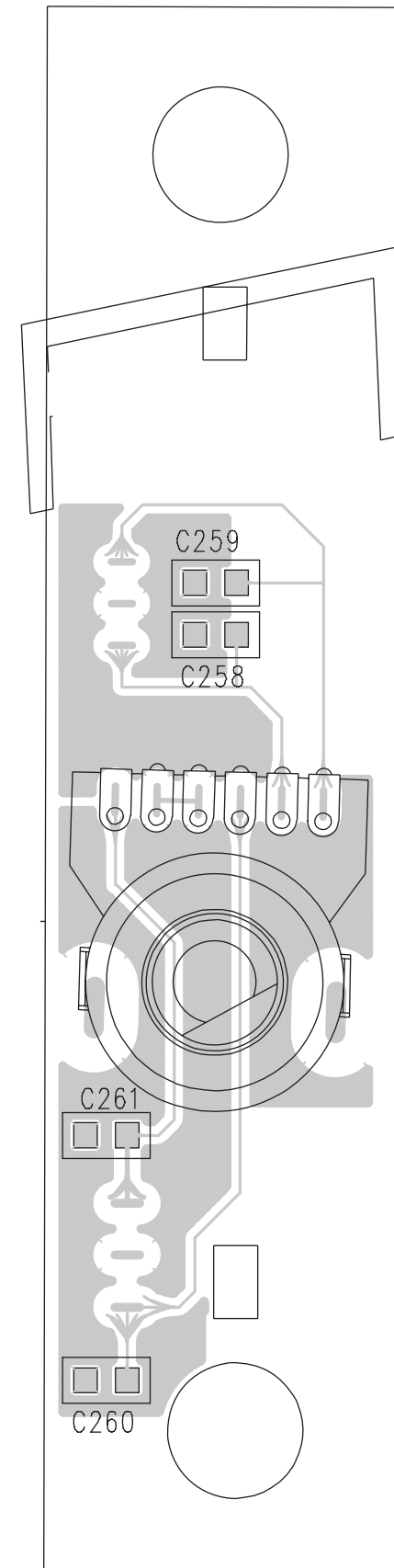

LCD BOARD - CIRCUIT DIAGRAM

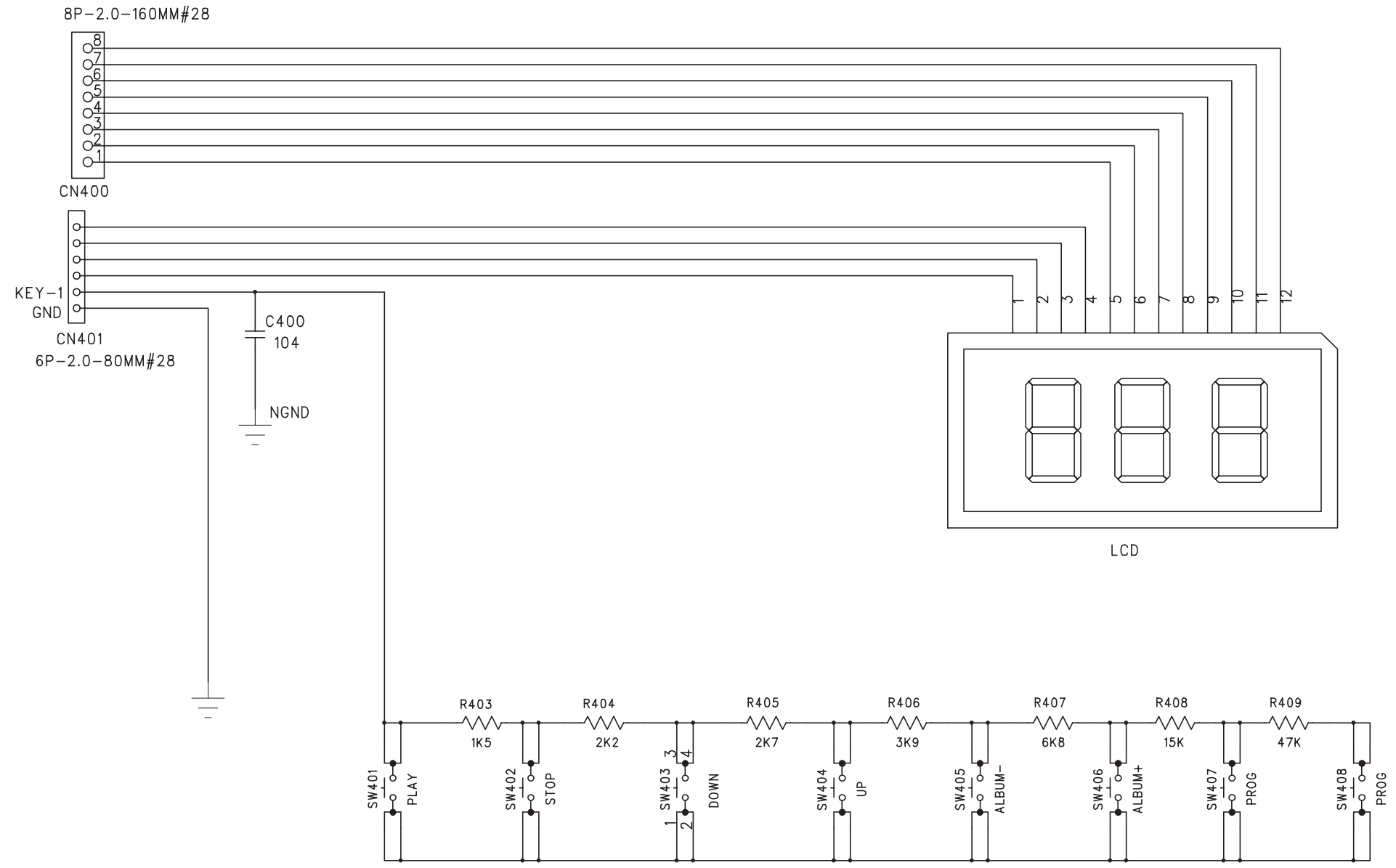

LCD BOARD - LAYOUT DIAGRAM

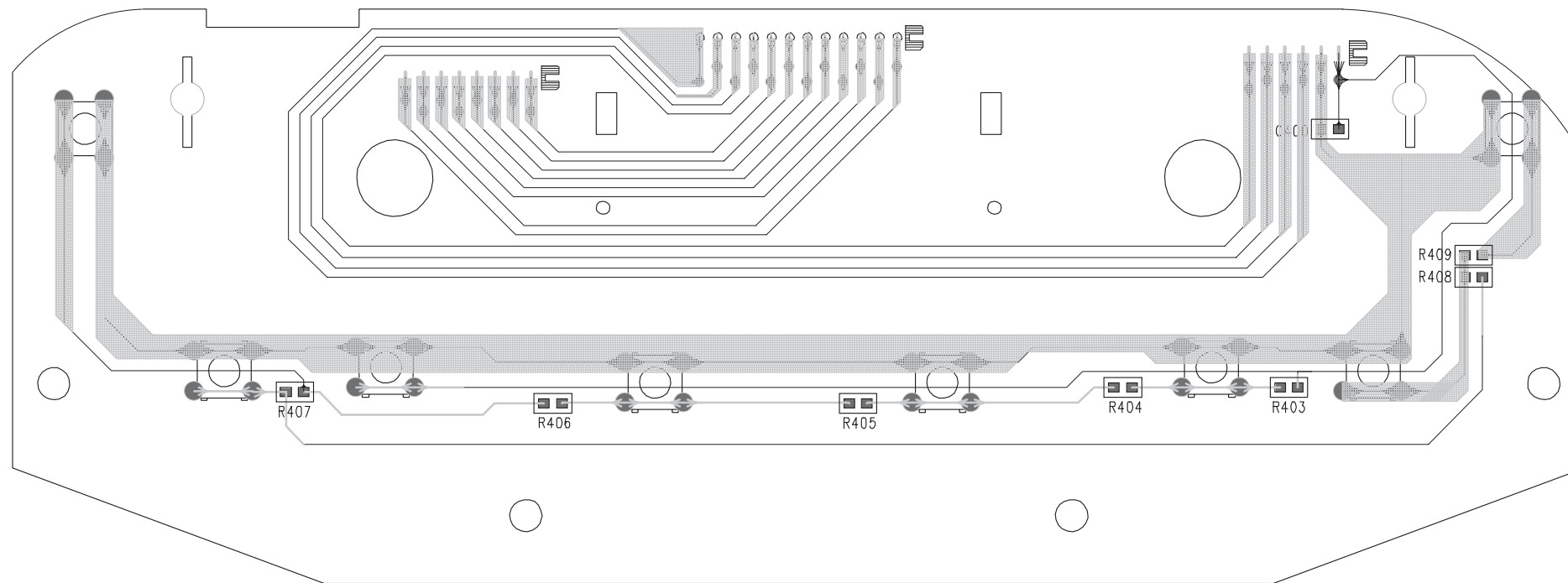
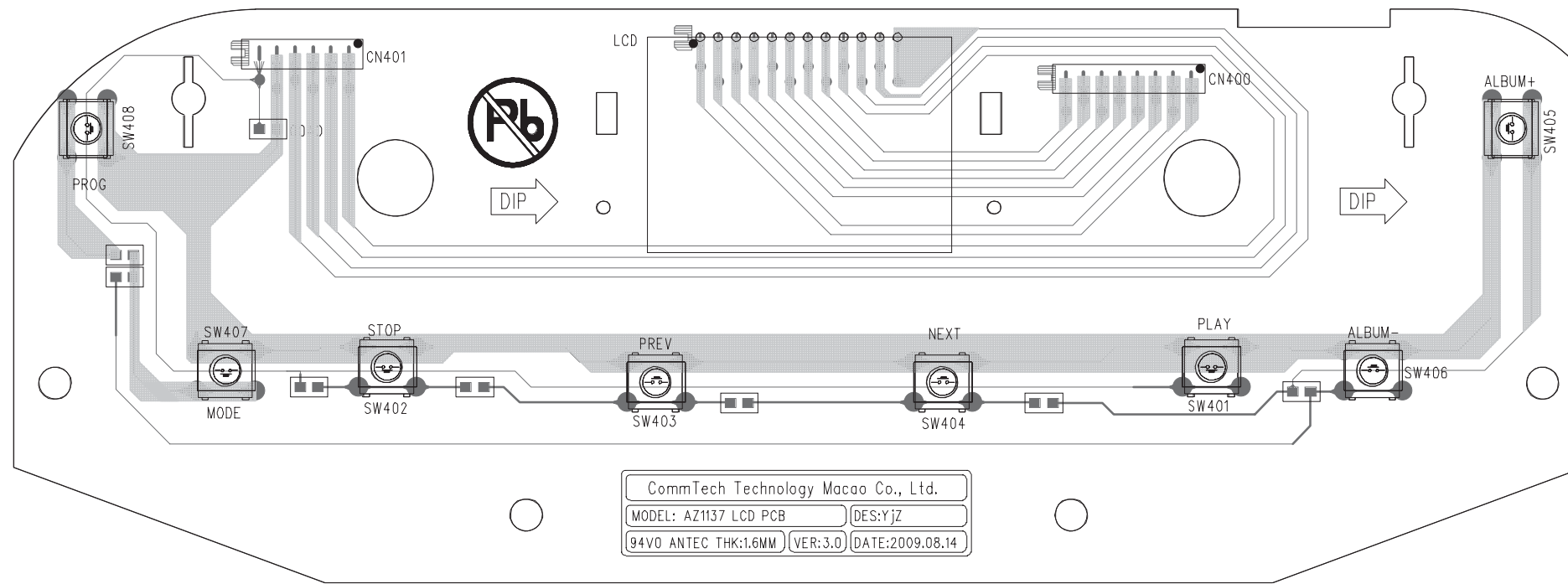

MAIN BOARD - CIRCUIT DIAGRAM (AMP PART)

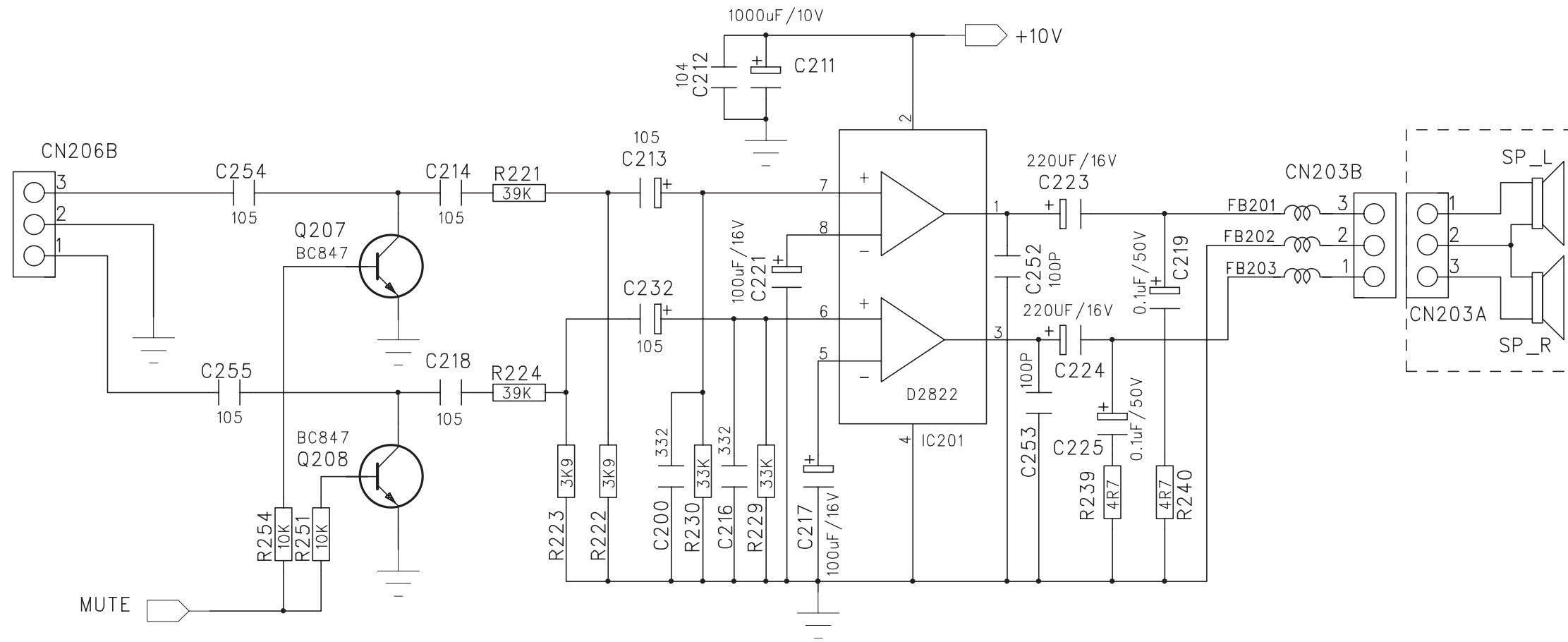

MAIN BOARD - CIRCUIT DIAGRAM
(BUFFER PART)

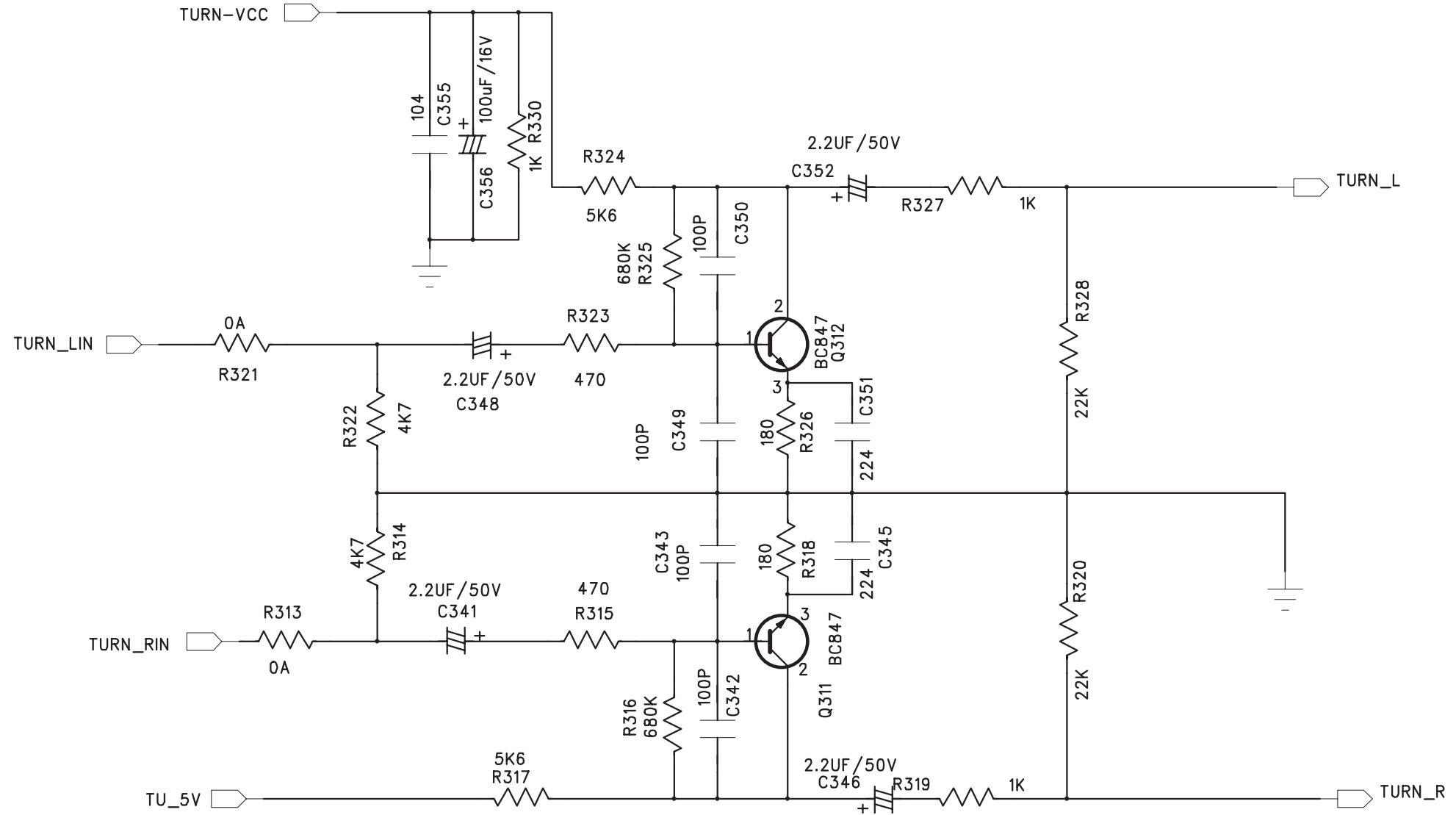

MAIN BOARD - CIRCUIT DIAGRAM
(CD PART)

Note 1 (P1-3: 6pin)

A/D value (MVDD=3.3V)	PUH	WMA	Display
0.00[V] (0.00 - 0.23[V])	SANYO DA11VF	Enable	Folder
0.35[V] (0.23 C 0.64[V])	SANYO DA11VF	Enable	Absolute Track
0.82[V] (0.64 - 1.16[V])	SANYO DA11VF	Disable	Folder
1.33[V] (1.16 C 1.62[V])	SANYO DA11VF	Disable	Absolute Track

Notes 2 (P2-0: 7pin)

A/D value (MVDD=3.3V)	MODE	DISPLAY	USB/REMOTE
2.45[V] (2.20 C 2.70[V])	Master	LCD	OTI MTP / RC5
3.30[V] (2.70 C 3.30[V])	Master	LCD	BP / TSB

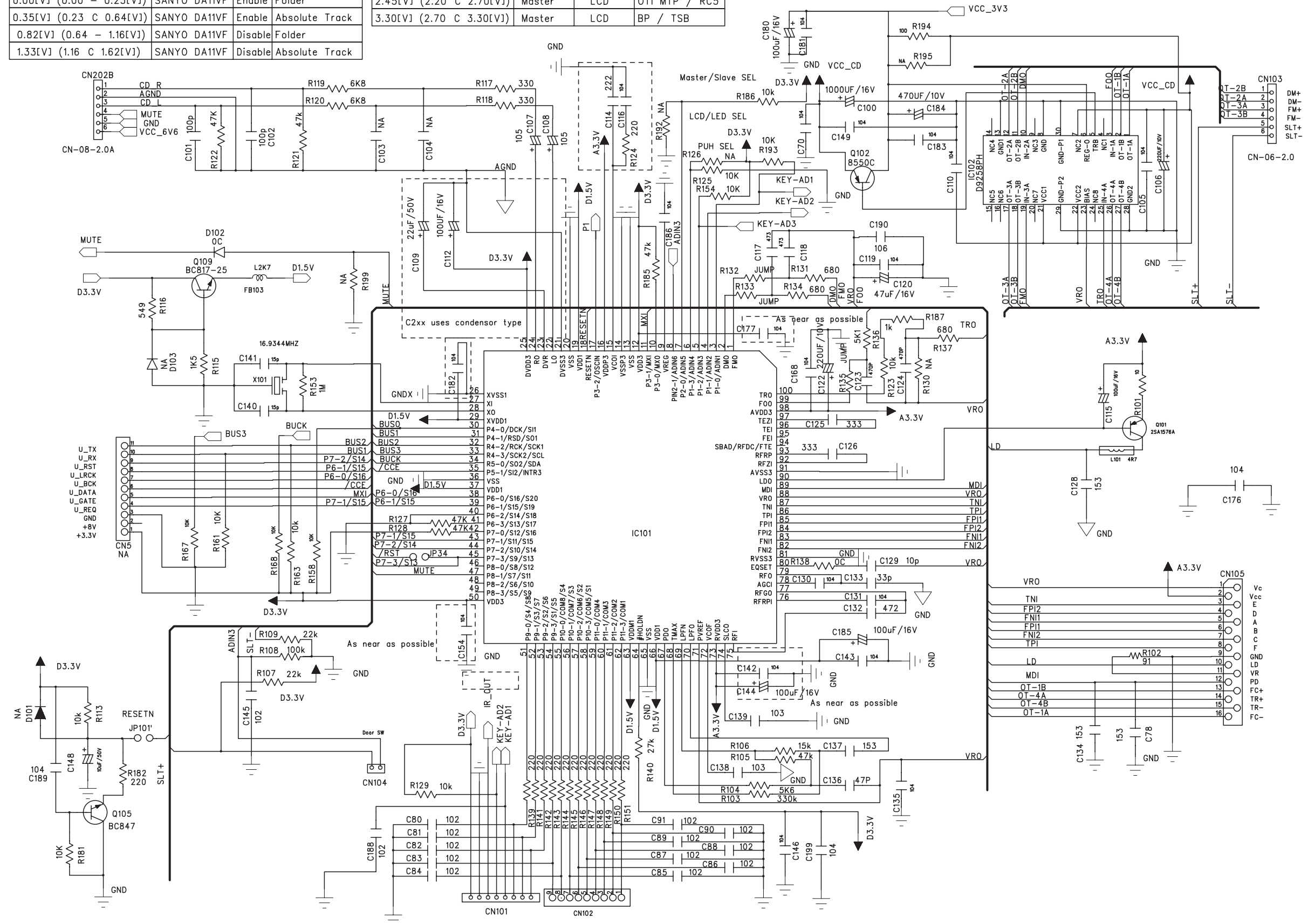

MAIN BOARD - CIRCUIT DIAGRAM (TUNER PART)

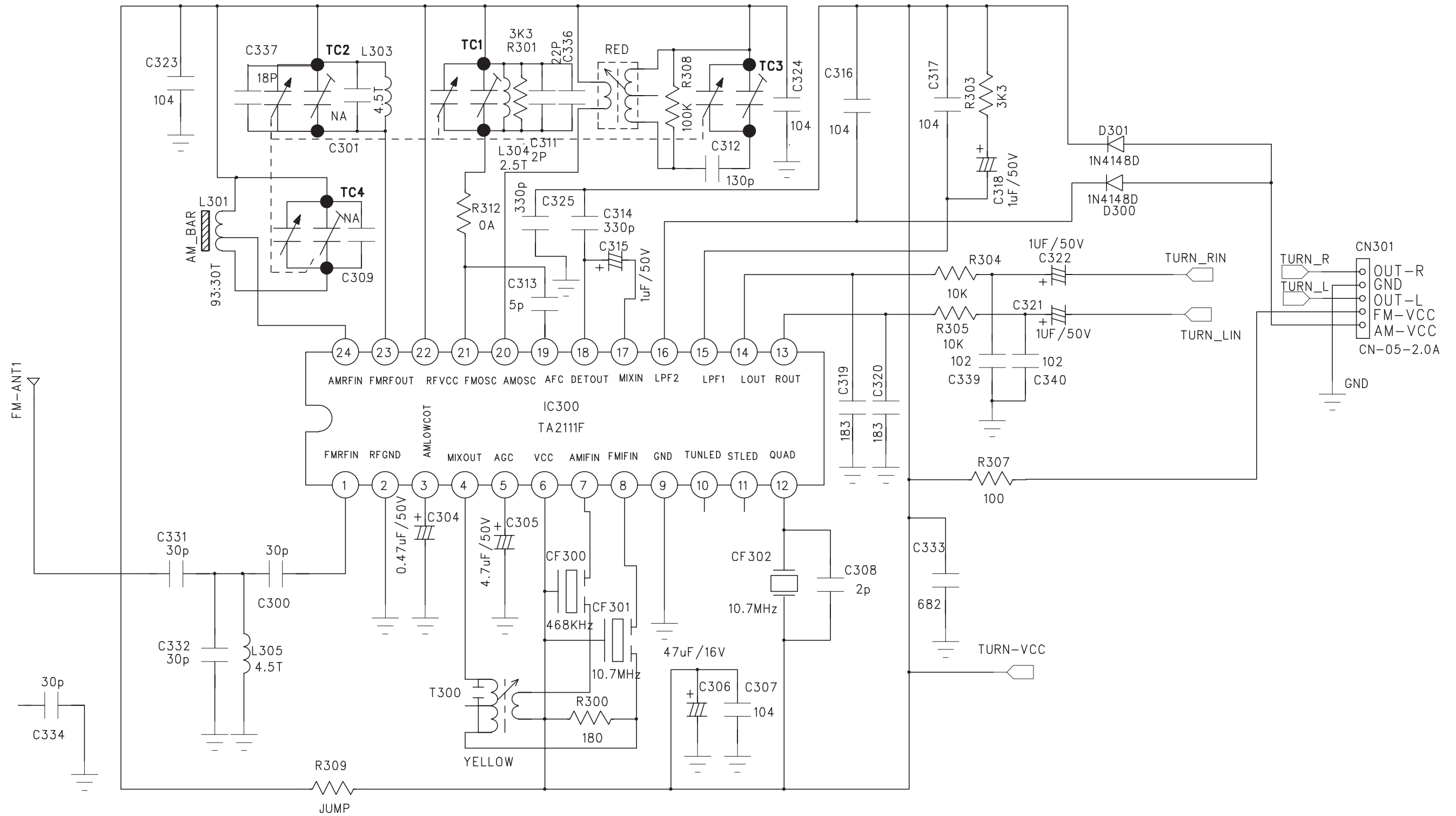

MAIN BOARD - LAYOUT DIAGRAM BOTTOM VIEW

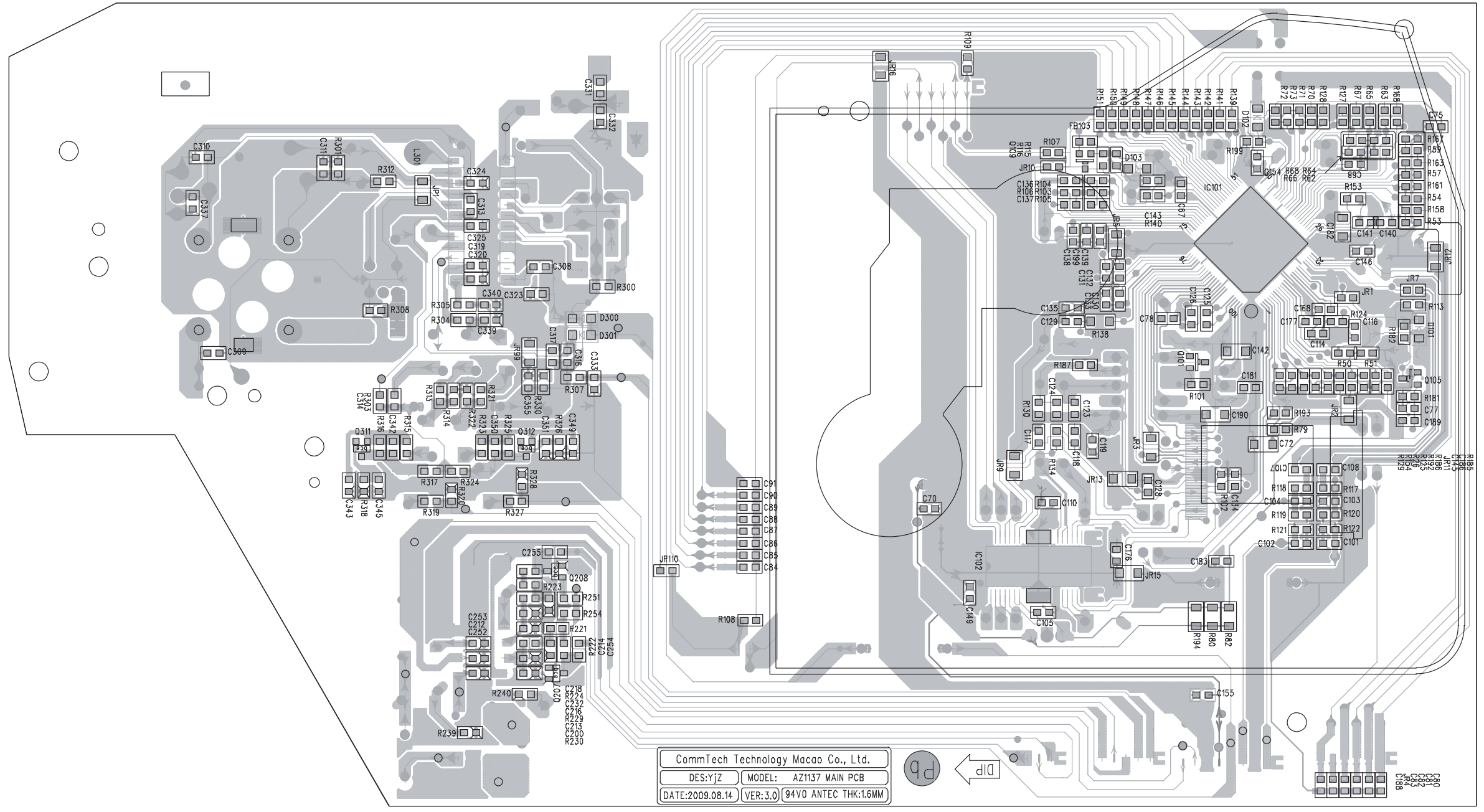

AUX BOARD - CIRCUIT DIAGRAM

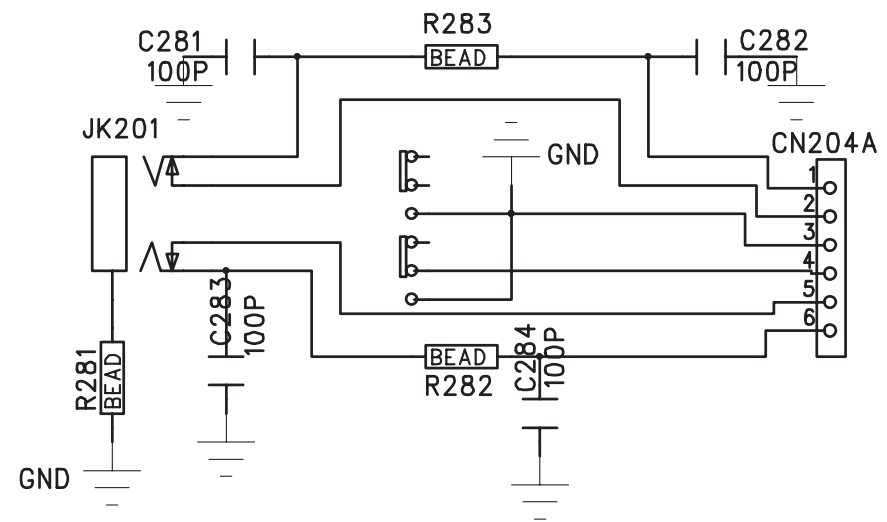

AUX BOARD - LAYOUT DIAGRAM
TOP VIEW

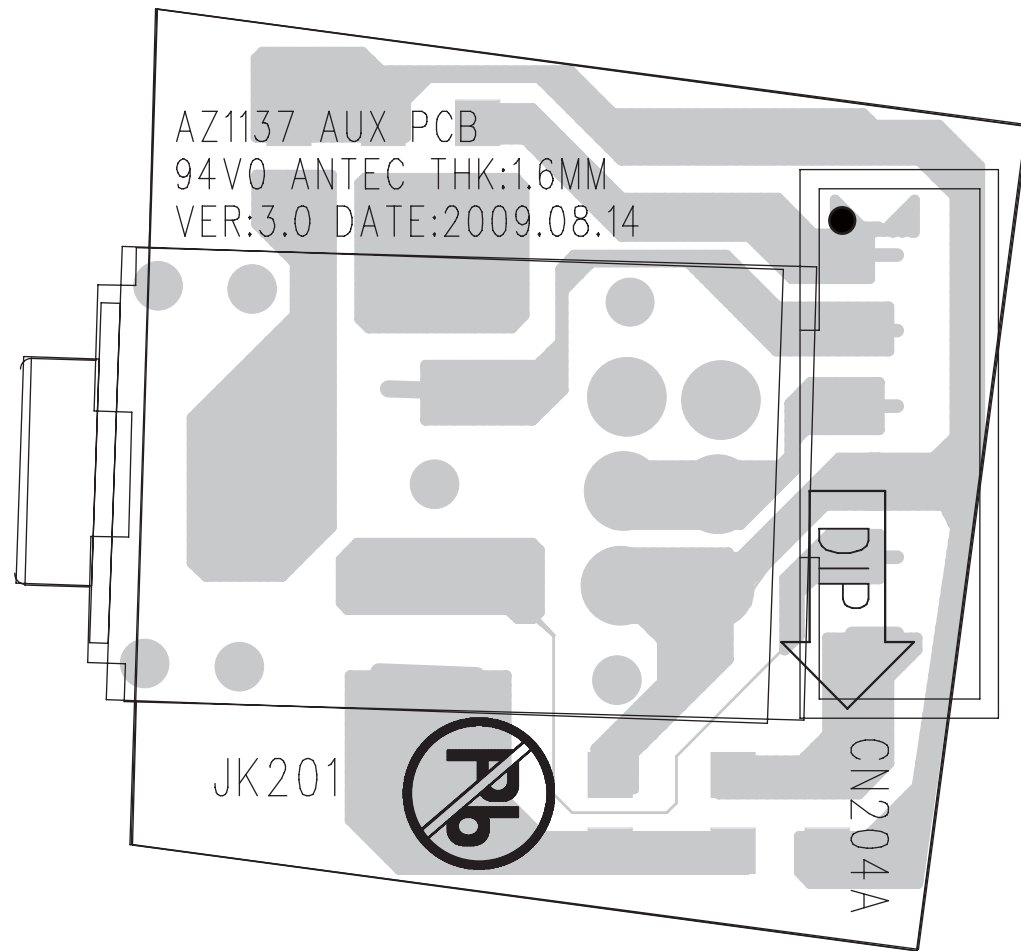

AUX BOARD - LAYOUT DIAGRAM
BOTTOM VIEW

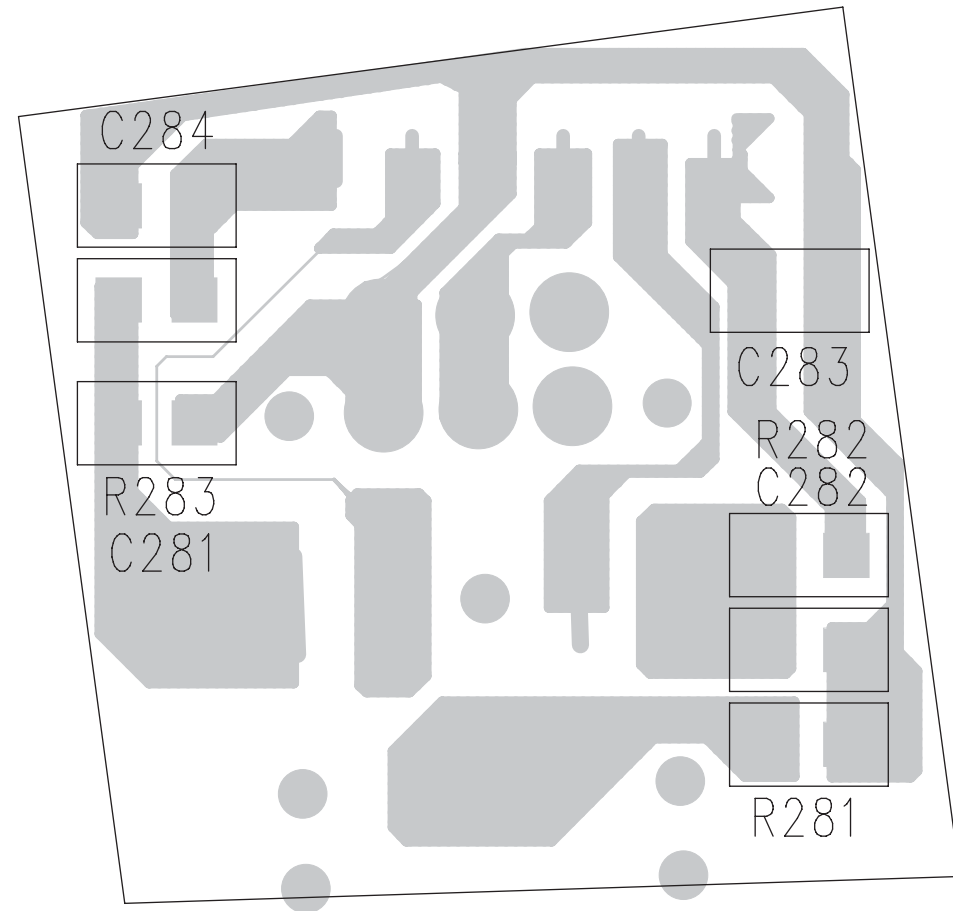

RECTIFIER BOARD - CIRCUIT DIAGRAM

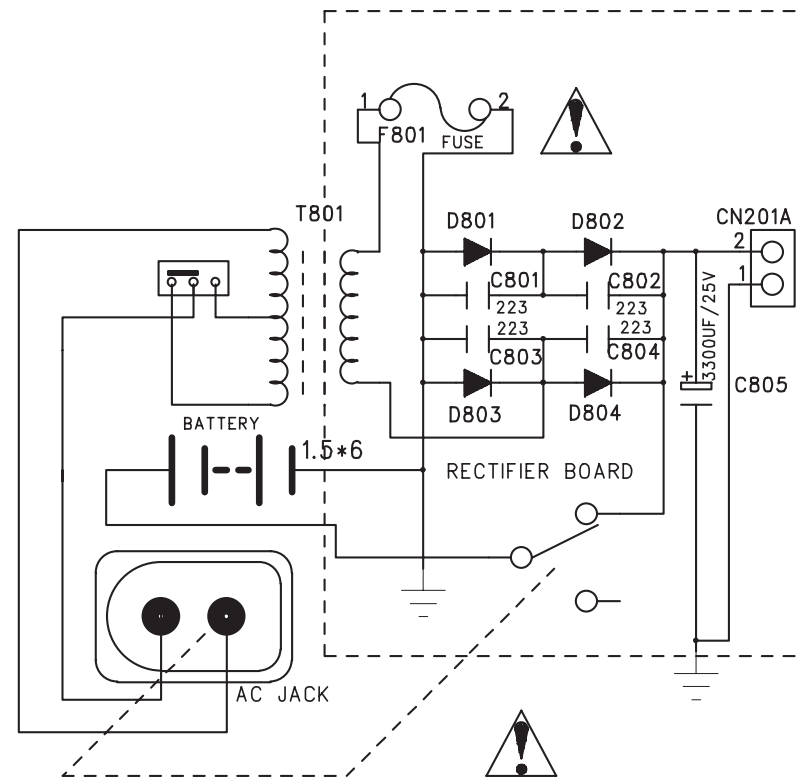

RECTIFIER BOARD - LAYOUT DIAGRAM
TOP VIEW

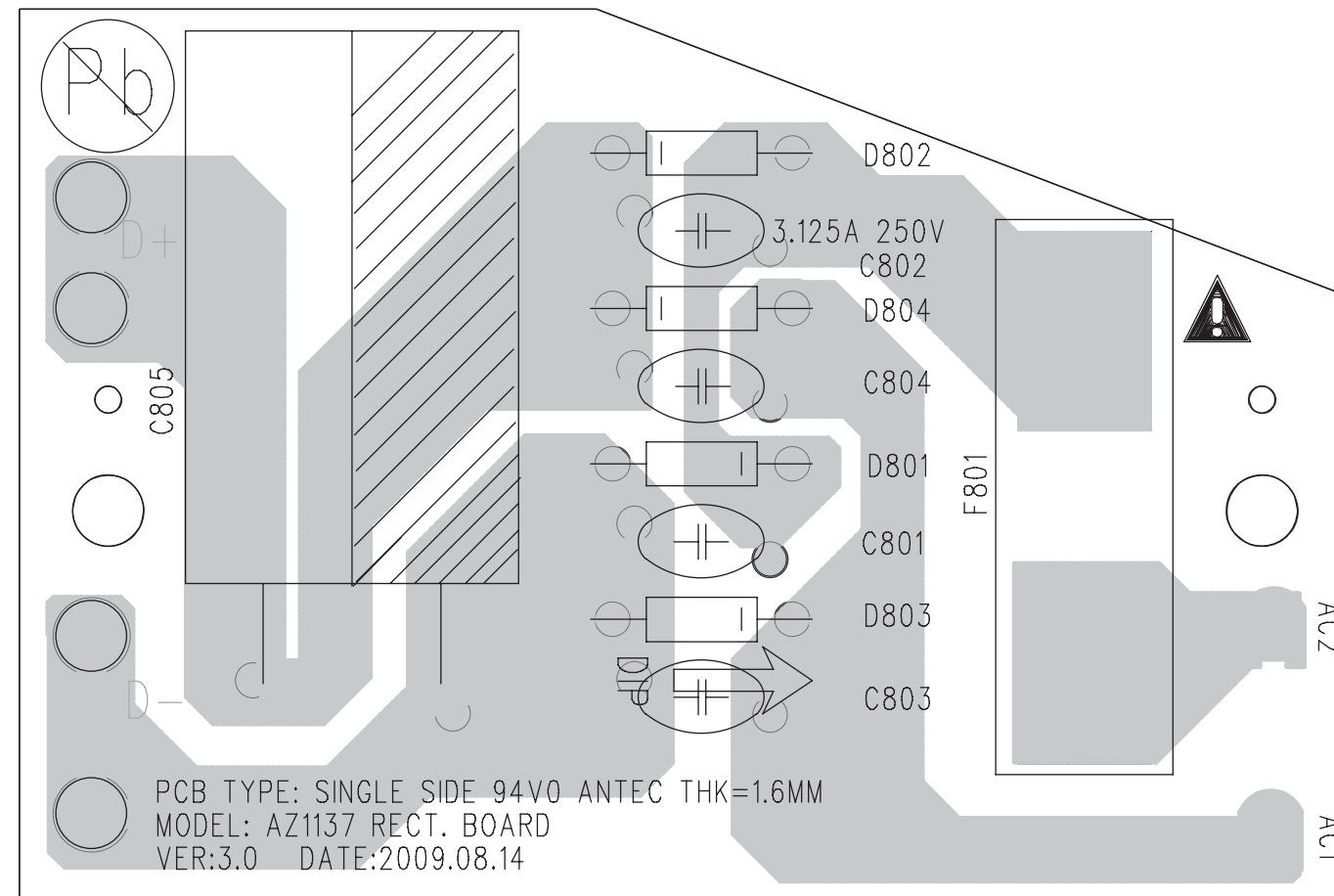

RECTIFIER BOARD - LAYOUT DIAGRAM
BOTTOM VIEW

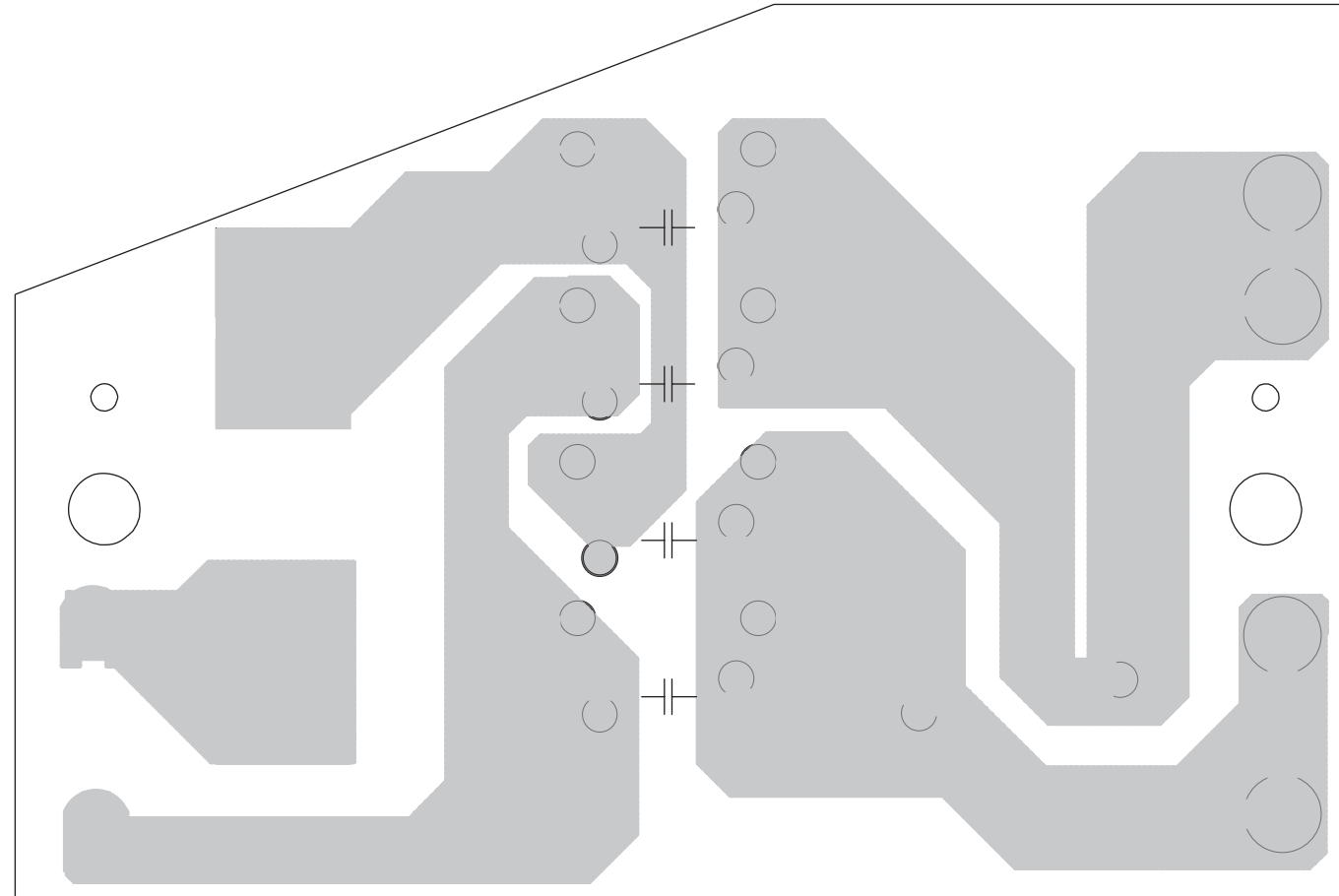

SET MECHANICAL EXPLODED VIEW

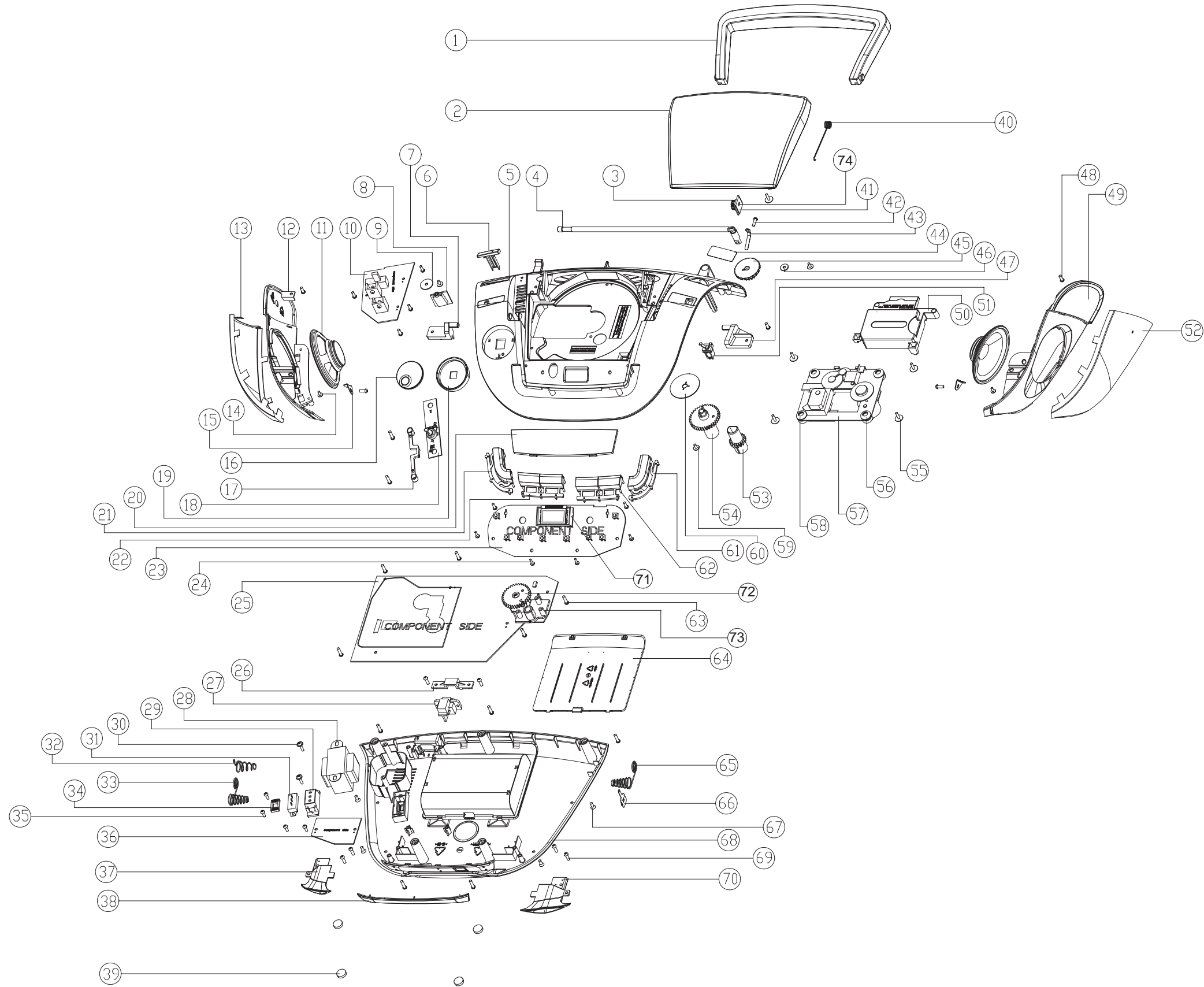

MECHANICAL & ACCESSORIES PARTS LIST(only for serial number NSxxxxxxx)

40	996510030507	CD DOOR SPRING
5	996510030535	TOP CABINET
68	996510030501	BOTTOM CABINET
64	996510030511	BATTERY DOOR
16	996510030508	VOLUMN KNOB
45	996510030529	TUNING KNOB
6	996510030532	SWITCH KNOB
21	996510030519	FUNCTION BUTTON A
22	996510030522	FUNCTION BUTTON B
62	996510030513	FUNCTION BUTTON C
61	996510030504	FUNCTION BUTTON D
56	996510030528	CD DAMPER GRN COLOR 658N
1	996510030502	HANDLE
20	996510030549	LENS LCD
37	996510030512	SOUND PIPE (L)
70	996510030516	SOUND PIPE (R)
2	996510030506	CD DOOR W/S.S
19	996510030527	VOL. DECO RING W/PLATE
38	996510030546	LENS PANEL W/PHILIPS
7	996510030537	ROTATE BRACKET L
47	996510030517	ROTATE BRACKET R
26	996510030531	AC SOCKET HOLDER
56	996510030528	CD DAMPER GRN COLOR 658N
17	996510030534	VOL-PCB-BRACKET
53	996510030541	TUNING GEAR B
54	996510030518	TUNING GEAR C
74	994000001409	CD DOOR GEAR HOLDER
3	996510000931	CD DOOR GEAR
73	996510030521	TUNING GEAR BRACKET
72	996510030536	TUNING GEAR A
71	996510030547	BRACKET LCD
3	994000005115	CD DAMPER BLACK 658PH
3	994000005115	CD DAMPER BLACK 658PH
34	996510030509	AC SELECTOR PLATE
29	996510021543	AC SELECTOR COVER
12	996510030526	LEFT CABINET
49	996510030515	RIGHT CABINET
ACCOIL	△ 996510018690	1.5M VDE POWER CORD
ANT1	994000003393	ROD ANTENNA 2-SECTIONS L=420MM
CDM1	996510030505	CD MECHANISM DA11B3VZSS
LINE10	994000001423	16P FFC L=70MM P=1MM
LINE6	△ 996510000935	2 PINS PLUG ADAPTOR
LINE7	996510001906	AUX STEREO CORD BLACK
SP1	996510030538	77MM SPEAKER 8R 1W 3INCH
SP2	996510030538	77MM SPEAKER 8R 1W 3INCH
SW	△ 996510000874	VOLTAGE SELECTOR WS-12J01-GC7
SW1	994000001422	CD DOOR SWITCH 1P1T
T801	△ 994000003395	TRANSFORMER EI-41 120/230V
A	996510030523	PCBA MAIN & AUX & RECT
B	996510030533	PCBA POWER

Note: Only these parts mentioned in the list are normal service parts.

ELECTRICAL PARTSLIST(only for serial number NSxxxxxxx)**PCBA MAIN & AUX & RECT**

CN105	996510021555	FFC SOCKET P1.0MM (ANGLE TYPE)
D300	996510010774	DIODE 1N4148 FDLL4148
D301	996510010774	DIODE 1N4148 FDLL4148
IC101	996510021518	IC TC94A77FG-612
IC102	994000005753	I.C. D9258PH
IC201	996510018432	IC D2822N
IC300	996510018433	IC TA2111NG
JK201	996510003840	3.5MM STEREO JACK
Q101	996510030539	TRANSISTOR 2SA1576A
Q102	996510003718	TRANSISTOR KTC-8550C
Q105	996510024762	TRANSISTOR KTC9014S
Q109	996510030525	TRANSISTOR BC817-40 SOT23
Q207	996510024762	TRANSISTOR KTC9014S
Q208	996510024762	TRANSISTOR KTC9014S
Q311	996510024762	TRANSISTOR KTC9014S
Q312	996510024762	TRANSISTOR KTC9014S
X101	996510011310	CERAMIC RESONATORZTA16.9344MHZ

PCBA POWER

D201	996510010774	DIODE 1N4148 FDLL4148
D2012	996510010774	DIODE 1N4148 FDLL4148
D203	996510010774	DIODE 1N4148 FDLL4148
D207	996510010774	DIODE 1N4148 FDLL4148
D208	996510010774	DIODE 1N4148 FDLL4148
D210	996510010774	DIODE 1N4148 FDLL4148
D213	996510010774	DIODE 1N4148 FDLL4148
DZ201	996510012835	ZENER DIODE 5V6 1/2W (TC5V6)
DZ202	996510011336	ZENER DIODE 7V5 1/2W (TC7V5)
Q201	996510001414	TRANSISTOR KTB772 (KEC) TAPE
Q202	996510024762	TRANSISTOR KTC9014S
Q203	996510012833	TRANSISTOR BC857B
Q204	996510003717	TRANSISTOR KTD882 (KEC)
Q210	996510030524	TRANSISTOR BC807-40 SOT23
Q212	996510024762	TRANSISTOR KTC9014S
SW202	996510018435	SLIDE SWITCH 4P4T

PCBA VR&LCD 94V0 ANTEC

LCD	996510021538	LCD DISPLAY 6H
SW401	996500039269	TACT SWITCH
SW402	996500039269	TACT SWITCH
SW403	996500039269	TACT SWITCH
SW404	996500039269	TACT SWITCH
SW405	996500039269	TACT SWITCH
SW406	996500039269	TACT SWITCH
SW407	996500039269	TACT SWITCH
SW408	996500039269	TACT SWITCH
VR201	996510030514	ROTARY VOLUME F-122KGP

Note: Only these parts mentioned in the list are normal service parts.

ELECTRICAL PARTSLIST(only for serial number NSxxxxxxx)**PCBA RECT**

C805	994000003217	AL.E.CAP 3300UF 25V
D801	996510011339	DIODE 1N4003
D802	996510011339	DIODE 1N4003
D803	996510011339	DIODE 1N4003
D804	996510011339	DIODE 1N4003
F801	 996510018427	FUSE 1.6A 250V D5X20MM

Note: Only these parts mentioned in the list are normal service parts.

Service
Service
Service



It is only for serial number XUxxxxxxx

Service Manual



TABLE OF CONTENTS

	Page
Version Variation.....	1-2
Technical specification	1-3..1-14
Safety instruction.....	2-1
ESD protection.....	2-2
Set Block diagram	3-1
Set Wiring diagram.....	4-1
Circuit diagram.....	5-1..5-3
Layout diagram.....	6-1..6-2
Mechanical Exploded view.....	7-1

© Copyright 2012 Philips Consumer Electronics B.V. Eindhoven, The Netherlands
All rights reserved. No part of this publication may be reproduced, stored in a retrieval system or transmitted, in any form or by any means, electronic, mechanical, photocopying, or otherwise without the prior permission of Philips.



2.0 SAFETY INSTRUCTIONS

(GB) WARNING

All ICs and many other semi-conductors are susceptible to electrostatic discharges (ESD). Careless handling during repair can reduce life drastically. When repairing, make sure that you are connected with the same potential as the mass of the set via a wrist wrap with resistance. Keep components and tools also at this potential.

ESD**(NL)** WAARSCHUWING

Alle IC's en vele andere halfgeleiders zijn gevoelig voor electrostatische ontladingen (ESD). Onzorgvuldig behandelen tijdens reparatie kan de levensduur drastisch doen verminderen. Zorg ervoor dat u tijdens reparatie via een polsband met weerstand verbonden bent met hetzelfde potentiaal als de massa van het apparaat. Houd componenten en hulpmiddelen ook op ditzelfde potentiaal.

(F) ATTENTION

Tous les IC et beaucoup d'autres semi-conducteurs sont sensibles aux décharges statiques (ESD). Leur longévité pourrait être considérablement écourtée par le fait qu'aucune précaution n'est prise à leur manipulation. Lors de réparations, s'assurer de bien être relié au même potentiel que la masse de l'appareil et enfilez le bracelet serti d'une résistance de sécurité. Veiller à ce que les composants ainsi que les outils que l'on utilise soient également à ce potentiel.

(D) WARNUNG

Alle ICs und viele andere Halbleiter sind empfindlich gegenüber elektrostatischen Entladungen (ESD). Unsorgfältige Behandlung im Reparaturfall kann die Lebensdauer drastisch reduzieren. Veranlassen Sie, dass Sie im Reparaturfall über ein Pulsarmband mit Widerstand verbunden sind mit dem gleichen Potential wie die Masse des Gerätes. Bauteile und Hilfsmittel auch auf dieses gleiche Potential halten.

(I) AVVERTIMENTO

Tutti IC e parecchi semi-conduttori sono sensibili alle scariche statiche (ESD). La loro longevità potrebbe essere fortemente ridotta in caso di non osservazione della più grande cauzione alla loro manipolazione. Durante le riparazioni occorre quindi essere collegato allo stesso potenziale che quello della massa dell'apparecchio tramite un braccialetto a resistenza. Assicurarsi che i componenti e anche gli utensili con quali si lavora siano anche a questo potenziale.

(GB)

Safety regulations require that the set be restored to its original condition and that parts which are identical with those specified, be used.

"Pour votre sécurité, ces documents doivent être utilisés par des spécialistes agréés, seuls habilités à réparer votre appareil en panne".

(NL)

Veiligheidsbepalingen vereisen, dat het apparaat bij reparatie in zijn oorspronkelijke toestand wordt teruggebracht en dat onderdelen, identiek aan de gespecificeerde, worden toegepast.

**(F)**

Les normes de sécurité exigent que l'appareil soit remis à l'état d'origine et que soient utilisés les pièces de rechange identiques à celles spécifiées.

(GB) Warning !

Invisible laser radiation when open. Avoid direct exposure to beam.

(D)

Bei jeder Reparatur sind die geltenden Sicherheitsvorschriften zu beachten. Der Originalzustand des Geräts darf nicht verändert werden; für Reparaturen sind Original-Ersatzteile zu verwenden.

(S) Varning !

Osynlig laserstrålning när apparaten är öppnad och spårren är urkopplad. Beträkta ej strålen.

(I)

Le norme di sicurezza esigono che l'apparecchio venga rimesso nelle condizioni originali e che siano utilizzati i pezzi di ricambio identici a quelli specificati.

(SF) Varoitus !

Avatussa laitteessa ja suojalukituksen ohitettaessa olet alltiina näkymättömälle laserisäteilylle. Älä katso säteeseen!

"After servicing and before returning set to customer perform a leakage current measurement test from all exposed metal parts to earth ground to assure no shock hazard exist. The leakage current must not exceed 0.5mA."

DK Advarsel !

Usynlig laserstrålning ved åbning når sikkerhedsafbrydere er ude af funktion. Undgå udsættelse for strålning.

Caution: These servicing instructions are for use by qualified service personnel only.

To reduce the risk of electric shock do not perform any servicing other than that contained in the operating instructions unless you are qualified to do so.

2.1 ESD PROTECTION

- レンズには絶対に触れないでください。
- DO NOT TOUCH THE LENS.
- LINSE NICHT BRÜHREN.
- NE PAS TOUCHER LA LENTILLE.

When the power supply is being turned on, you may not remove this laser cautions label. If it removes, radiation of laser may be received.

PREPARATION OF SERVICING

Pickup Head consists of a laser diode that is very susceptible to external static electrocity.

Although it operates properly after replacement, if it was subject to electrostatic discharge during replacement, its life might be shortened. When replacing, use a conductive mat, soldering iron with ground wire, etc. to protect the laser diode form damage by static electricity.

And also, the LSI and IC are same as above.

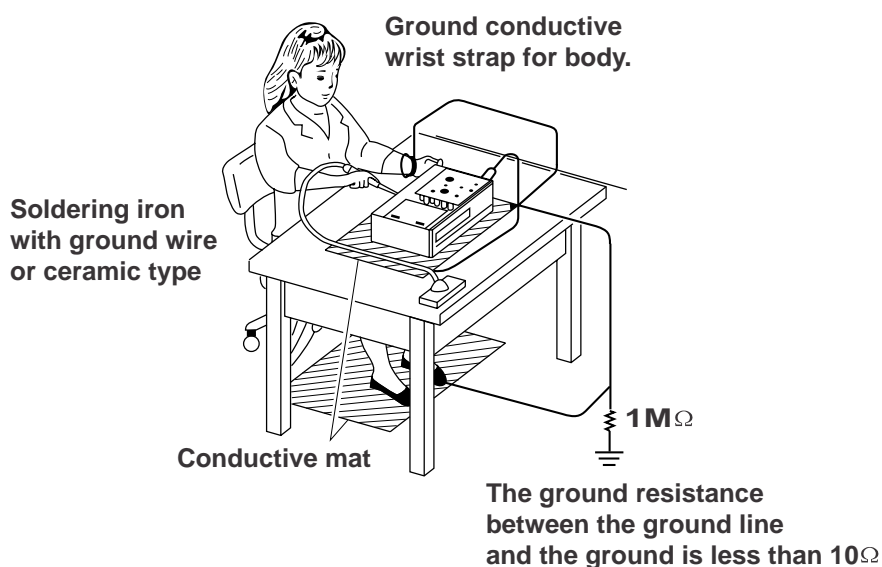

SAFTY NOTICE

SAFTY PRECAUTIONS

LEAKAGE CURRENT CHECK

Plug the AC line cord directly into a 120V AC outlet (do not use an isolation transformer for this check). Use an AC voltmeter, having 5000Ω per volt or more sensitivity. Connect a 1500Ω 10W resistor, paralleled by a $0.15\mu\text{F}$ 150V AC capacitor between a known good earth ground (water pipe, conduit, etc.) and all exposed metal parts of cabinet (antennas, handle bracket, metal cabinet screwheads, metal overlays, control shafts, etc.).

Measure the AC voltage across the 1500Ω resistor. The test must be conducted with the AC switch on and then repeated with the AC switch off. The AC voltage indicated by the meter may not exceed 0.3V. A reading exceeding 0.3V indicates that a dangerous potential exists, the fault must be located and corrected. Repeat the above test with the DVD VIDEO PLAYER power plug reversed. NEVER RETURN A DVD VIDEO PLAYER TO THE CUSTOMER WITHOUT TAKING NECESSARY CORRECTIVE ACTION.

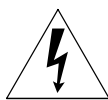
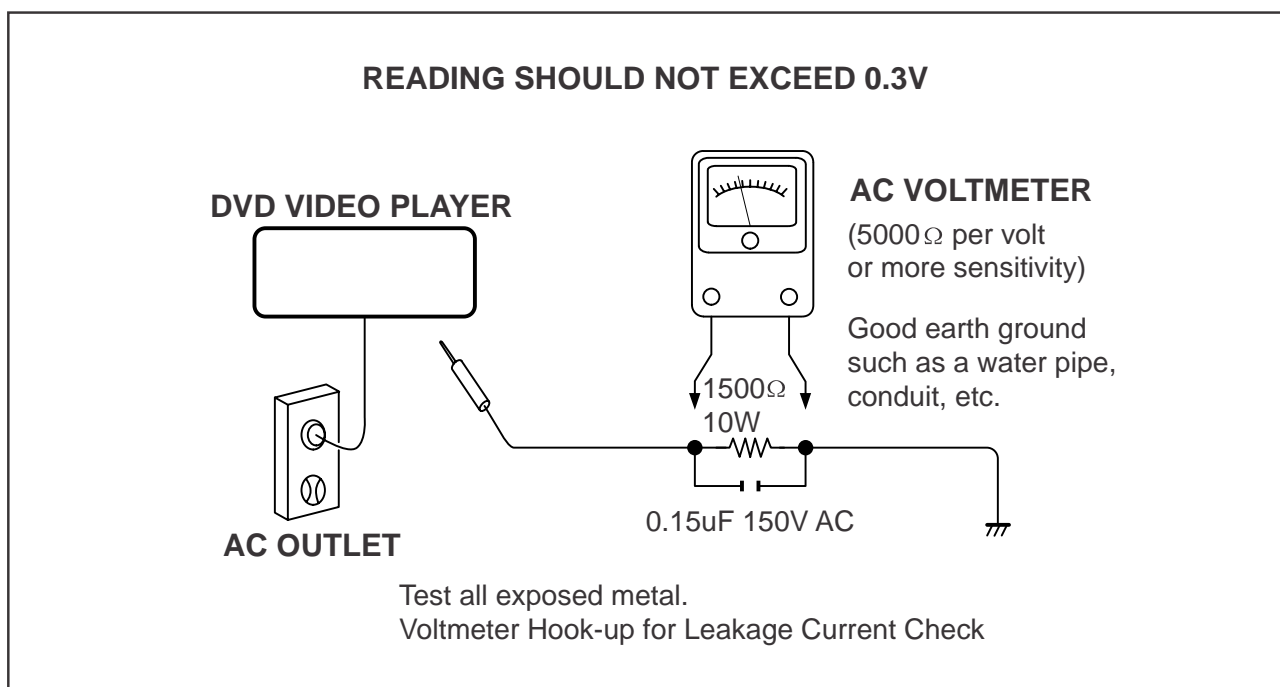

The lightning flash with arrowhead symbol, within an equilateral triangle, is intended to alert the user to the presence of uninsulated "dangerous voltage" within the product's enclosure that may be of sufficient magnitude to constitute a risk of electric shock to persons.



The exclamation point within an equilateral triangle is intended to alert the user to the presence of important operating and maintenance (servicing) instructions in the literature accompanying the appliance.

BLOCK DIAGRAM

3-1

3-1

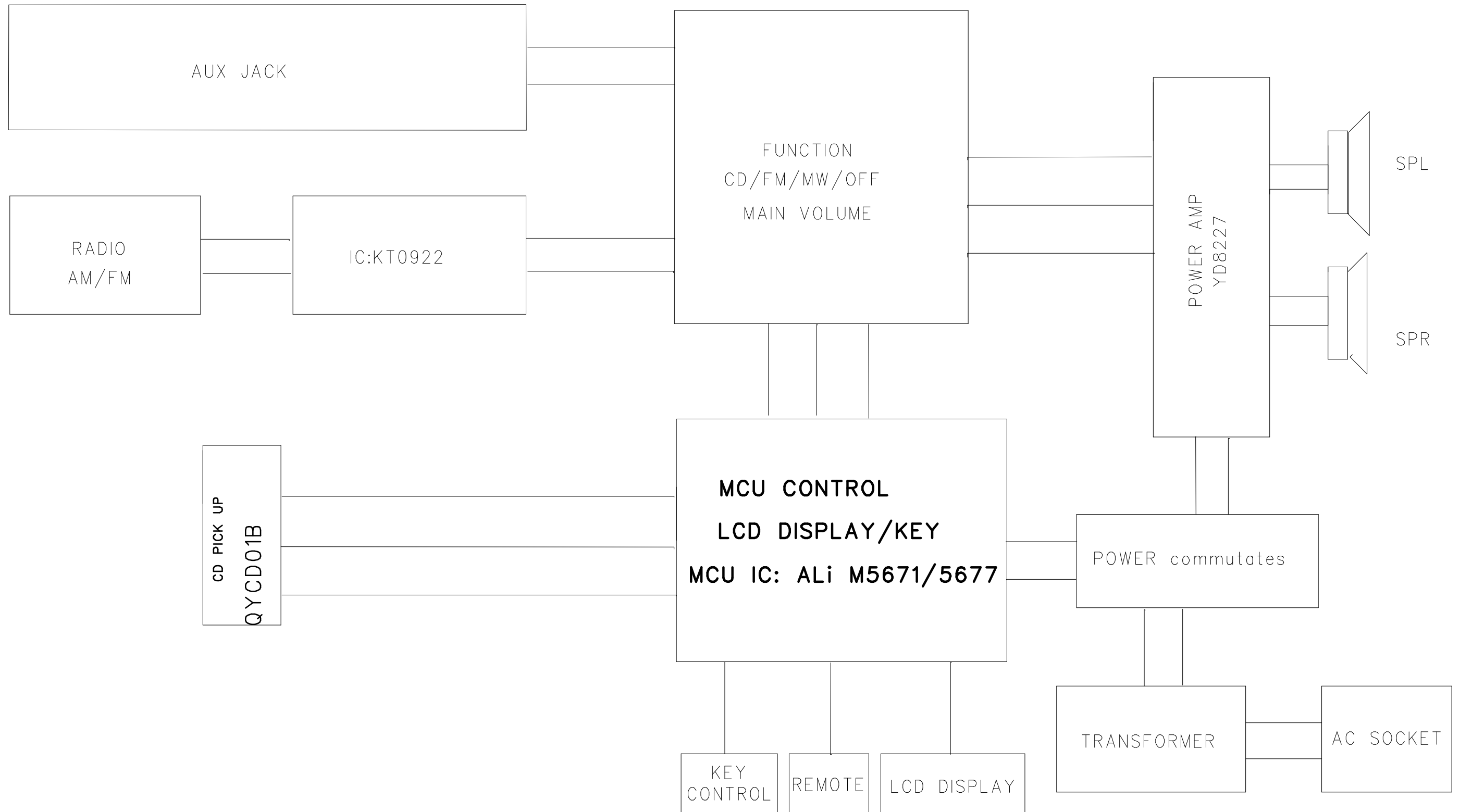

WIRING DIAGRAM

4-1

4-1

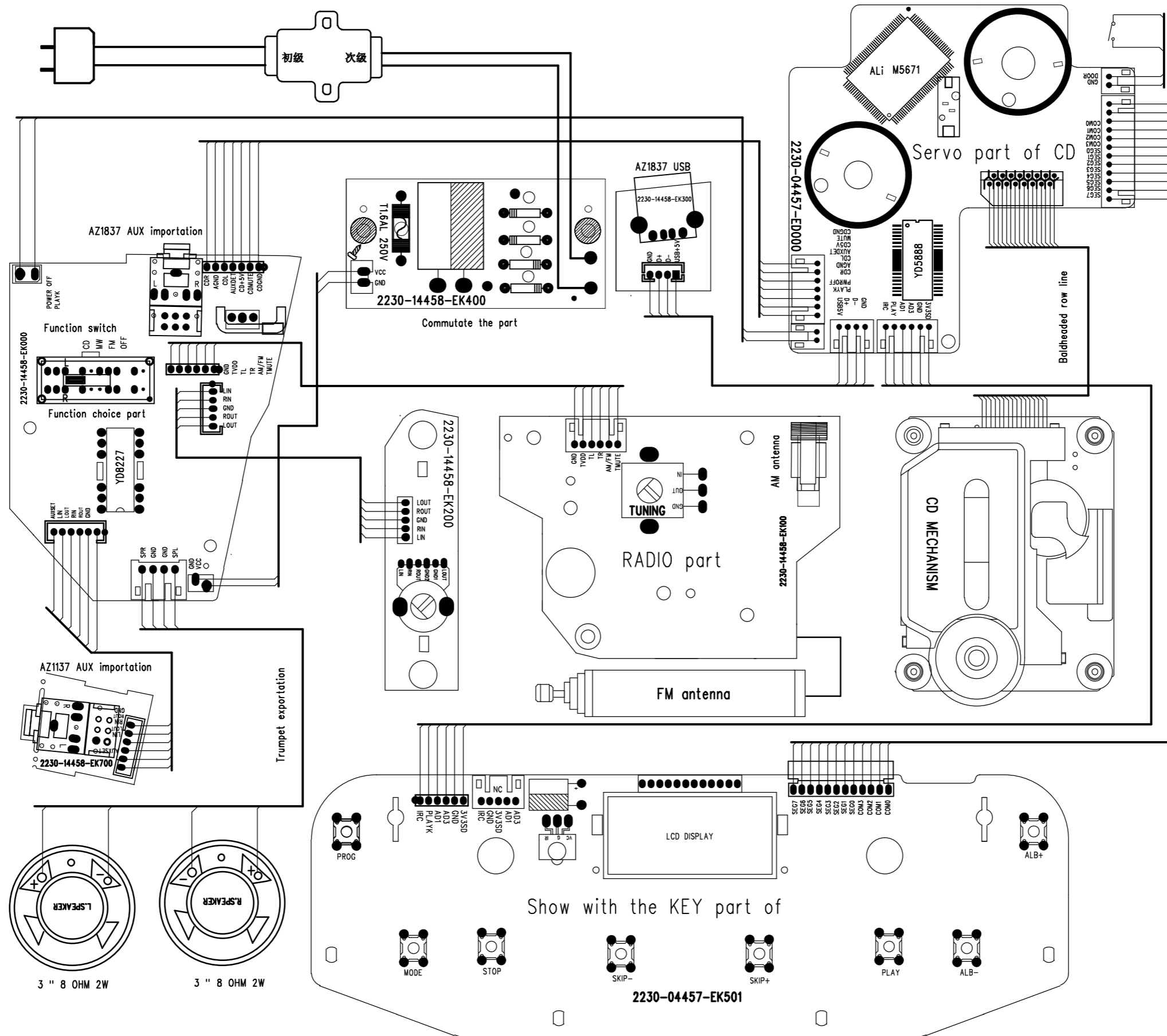

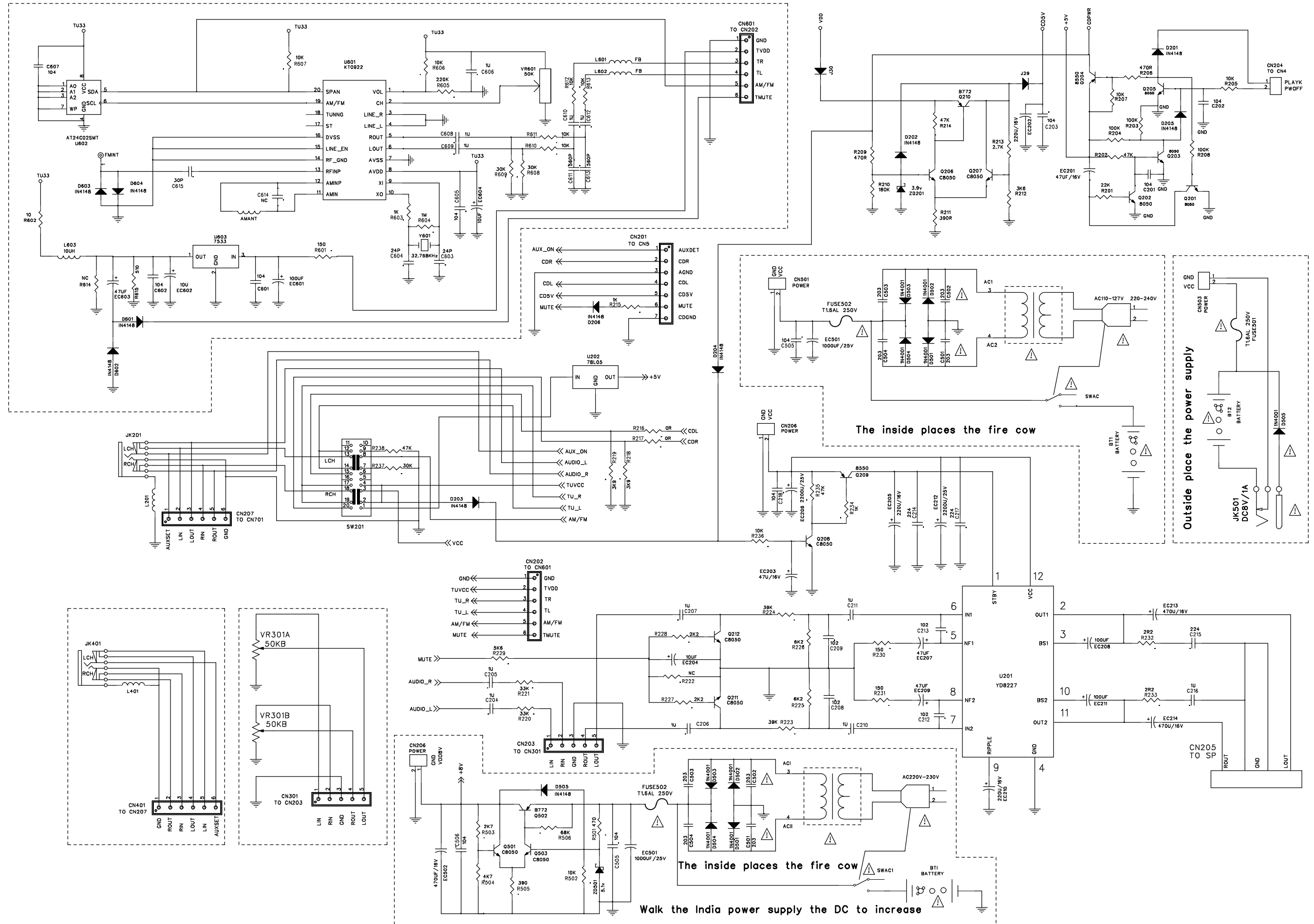

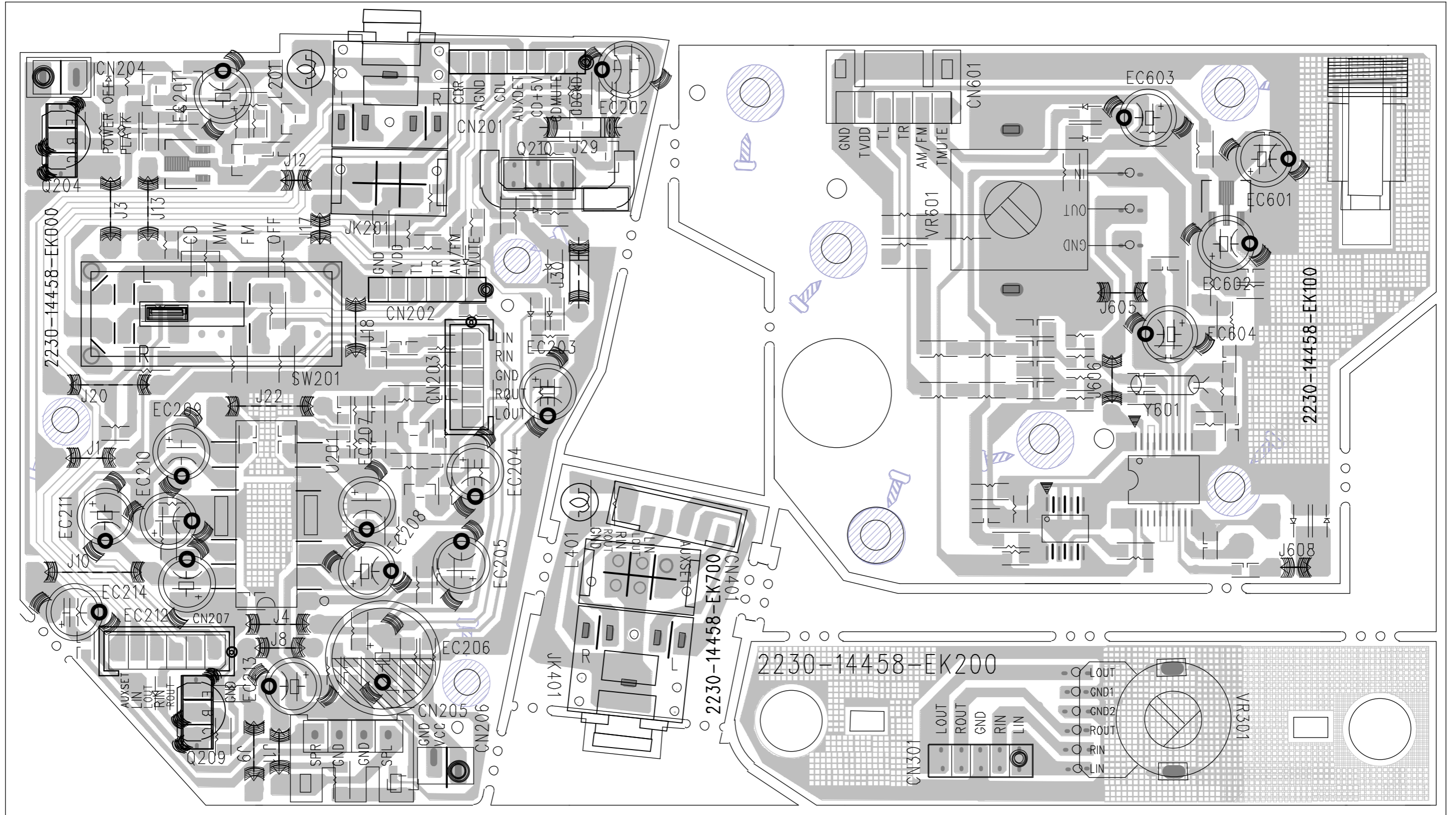

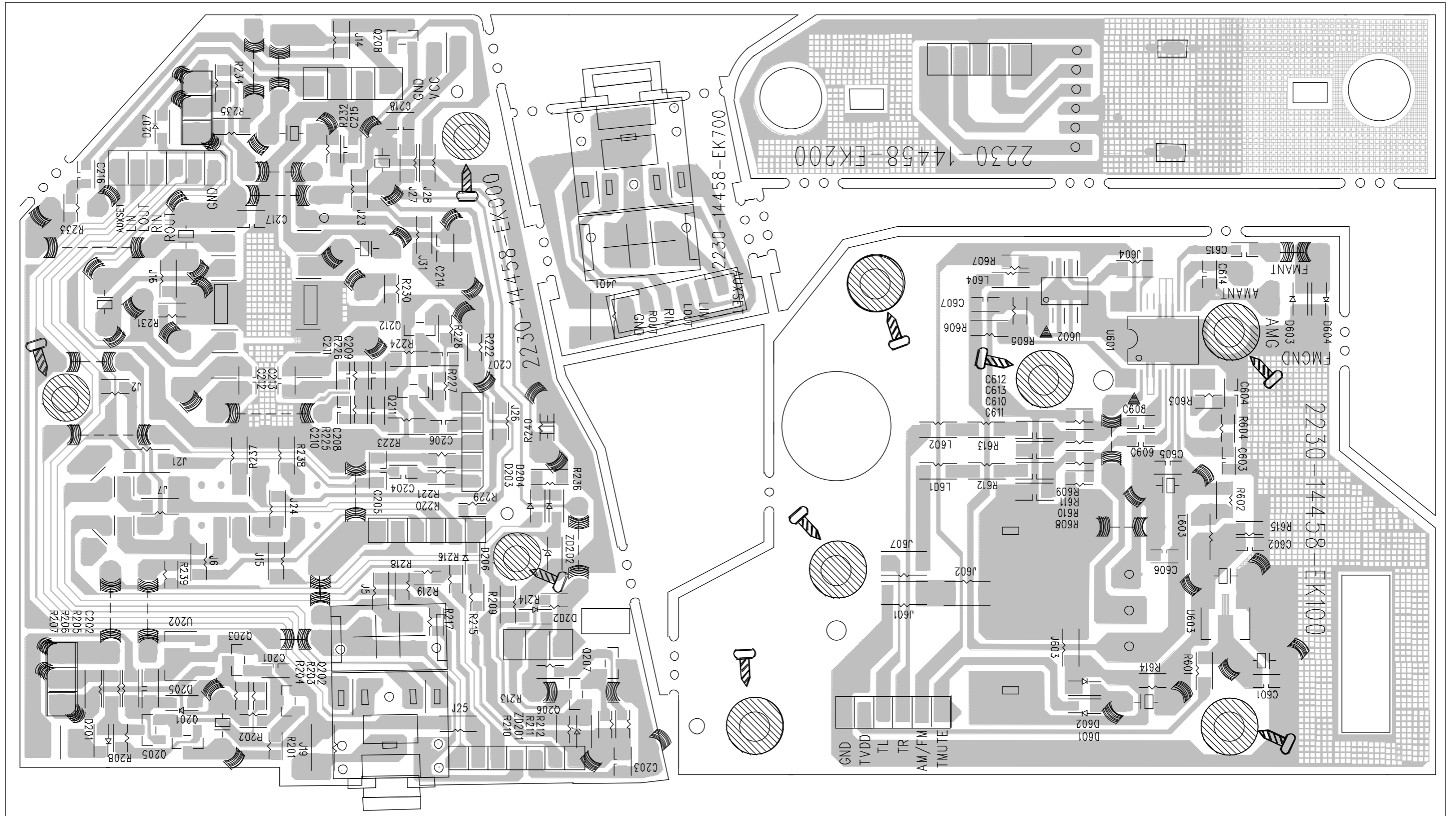

EXPLODED VIEW DIAGRAM

